



RAS
SAFETY | SECURITY | SERVICE



impro technologies[®]
ACCESS CONTROL

we access the **WORLD**

we access the **WORLD**

CONTENT

1. System Introduction
2. Understanding the system
3. Hardware
4. Configuration Options
5. apLITE configuration

CONTENT

1. system INTRODUCTION

- Basic system parameters & applications
- Terminology

ACCESS PORTAL LITE

ENTRY LEVEL MARKET
COST EFFECTIVE

It is a fully web based access control system, so everything you need is at your fingertips.

You can access the system **remotely** anytime via your **mobile, tablet** or **network**.

PARAMETERS

- Up To **1 000** Tagholders
- Up To **8** APB Doors or single entry out
- **1** Site
- **3** tags per person
- Up to **100 000** buffered transactions
- Up to **8** Tagholder access groups

www.impro.net



APPLICATIONS

Small offices | Commercial or Residential
Complexes | Doctor's rooms | Fuel Stations
Bed and Breakfast | Holiday rental property

ACCESS CONTROL

TERMINOLOGY

USED IN ACCESS PORTAL SYSTEMS

- Cluster Controller
- Reader Modules (Wiegand and Antenna)
- Door Readers
- Quick Connectors
- Ethernet/TCP/IP – RJ45
- RS485
- S-BUS
- Biometrics
- Tag holders
- BUFFERED Transactions
- Html 5
- Embedded Coding
- Embedded Controllers

CONTENT

2. Understanding the system

- **Features**
- **System Architecture**

SYSTEM FEATURES

ACCESS PORTAL LITE

Access Portal **LITE** offers you the best price to feature ratio in its market.

- Fully embedded web solution.
No PC or software is required
- Password protected and encrypted communications
- Connect to the controller using a standard HTML5 compliant browser
- Quick to install, simple to configure
- Storage of all tagholder details
- Web reporting
- Up to 8 access groups
- Door mode patterns
- Programmable holidays
- Tag enrolment
- Tag expiry date
- Tag suspension facilities
- Hardware identification and configuration
- AP Lite controller communication via TCP/IP

www.impro.net



ACCESS CONTROL

SYSTEM ARCHITECTURE - ACCESS PORTAL Lite

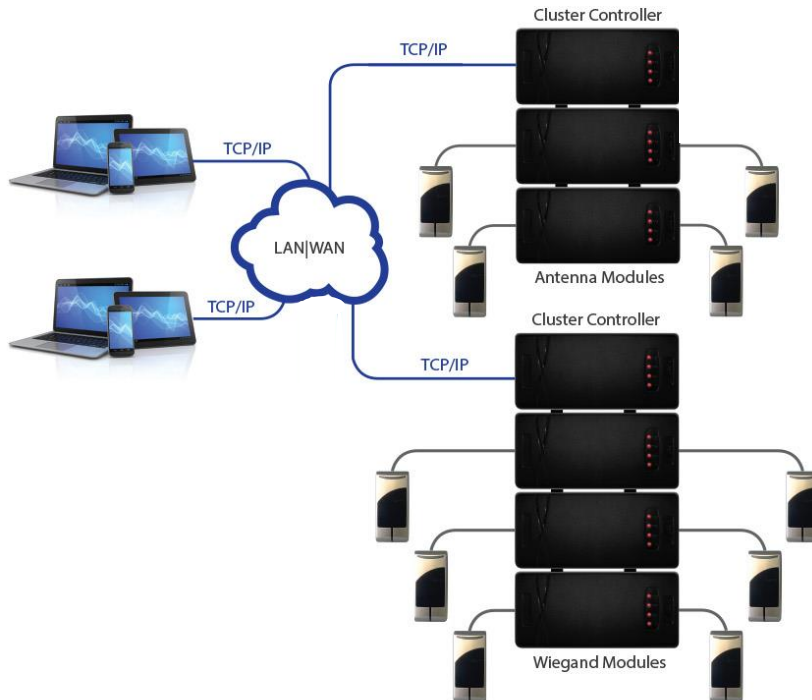

CONTENT

3. Hardware

- **Cluster Controller**
- **Wiegand Reader Module**
- **Antenna Reader Module**

CLUSTER CONTROLLER BASIC ARCHITECTURE

- Connects to additional Cluster Controllers via RS485 (1km)
- Connects to Reader Modules via Quick-Connector or S-Bus (150m)
- Up to 8 Reader Modules per Cluster Controller (16 Readers)

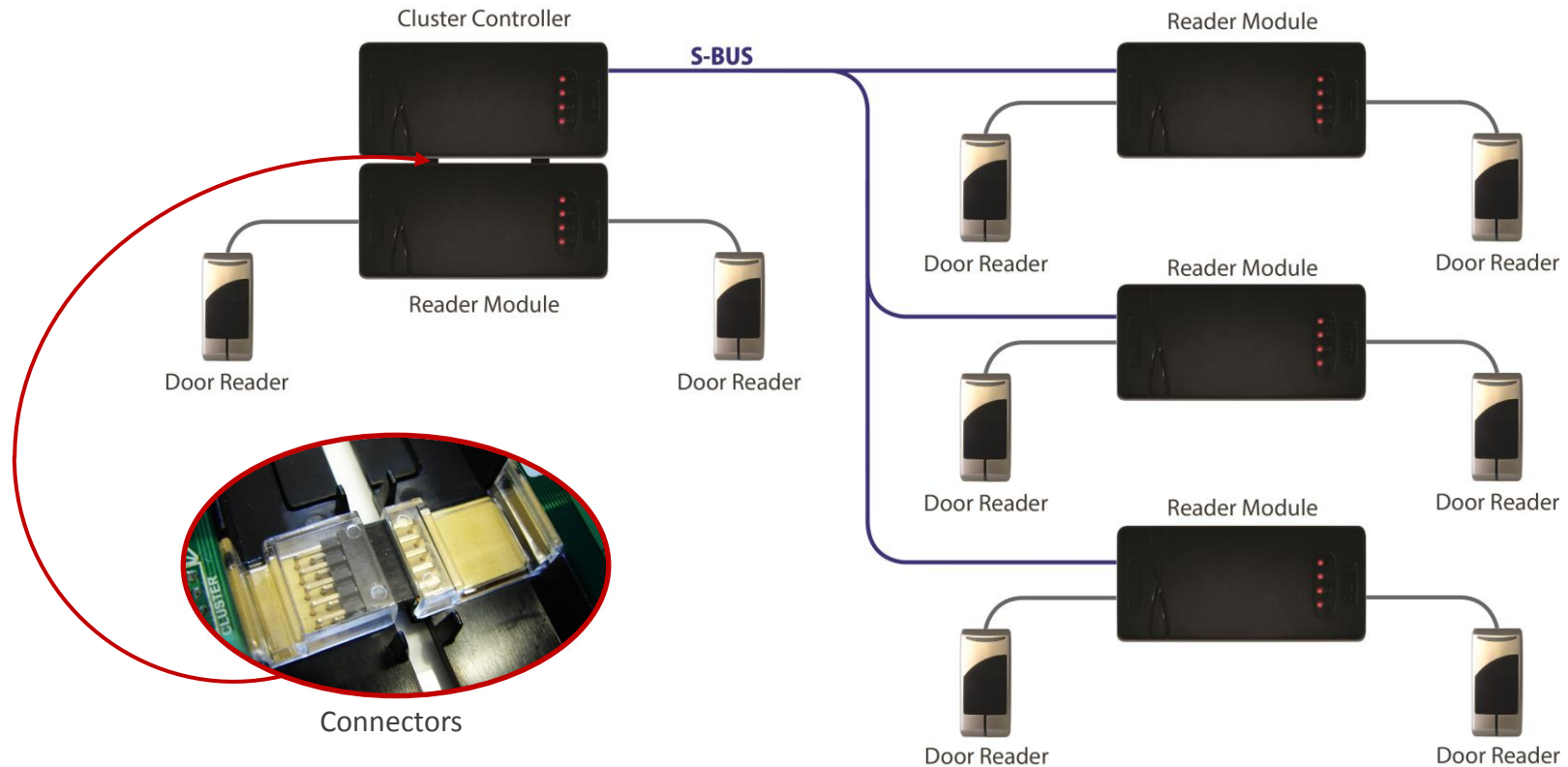

NEW HARDWARE COMPONENTS

CLUSTER CONTROLLER

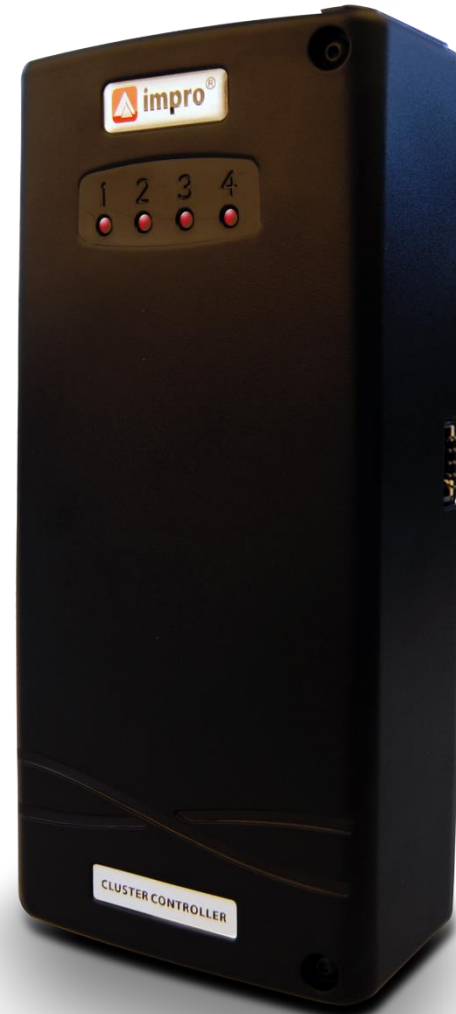

NEW HARDWARE COMPONENTS

CLUSTER CONTROLLER

FEATURES:

- Supported in **Access Portal LITE** , **PRO** and **ENTERPRISE** solutions for seamless upgrading
- Supports on board
 - Door Controller firmware
 - AP Lite embedded software
 - AP Lite firmware
 - AP Pro firmware
- Completely modular design for ultimate in-field configuration flexibility
- Industry first true plug & play hardware expansion
- Backwards compatible with Impro iTT and iTRT Door Controllers



NEW HARDWARE COMPONENTS

CLUSTER CONTROLLER

SPECIFICATIONS:

- apLITE supports full offline functionality for up to **1 000** Tagholders
- Supports up to **100 000** buffered transactions per Cluster Controller
- Compatible with both Antenna & Wiegand Reader Modules
- Supports up to 8 Reader Modules (16 readers) via
 - Quick-Connectors
 - S-Bus
- Supports the following:
 - Anti-Passback
 - Access rights
 - Emergency Mode
 - Lockdown Mode

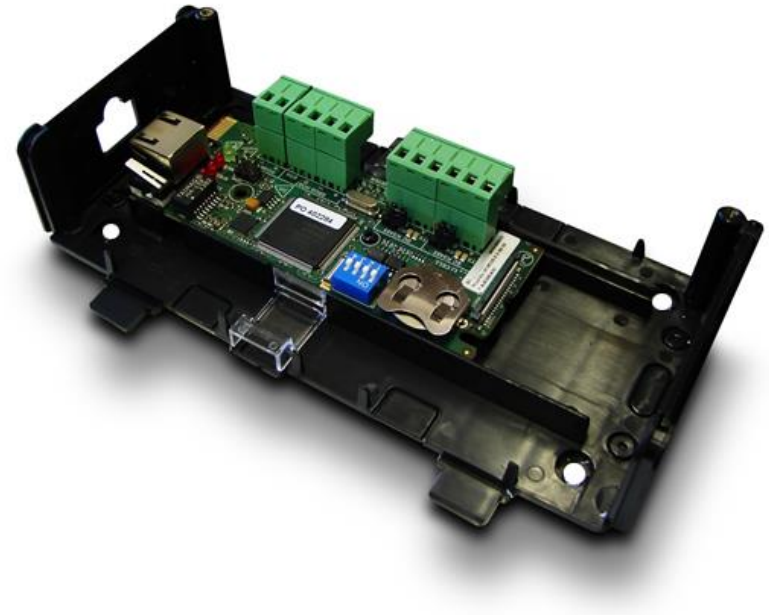

CLUSTER CONTROLLER

Specifications

The Cluster Controller provides all the Control, Communications, Tag Buffer and Memory required to run a Cluster of Expansion

Plastic Housing

Designed to work in an indoor (dry) environment similar to IP20.

The CCM is **not** sealed against water.

PCB Card for IPS Housing

Designed to work in an indoor (dry) environment similar to IP20.

The CCM is **not** sealed against water.

➤ **IP20 Not protected from liquids**

www.impro.net

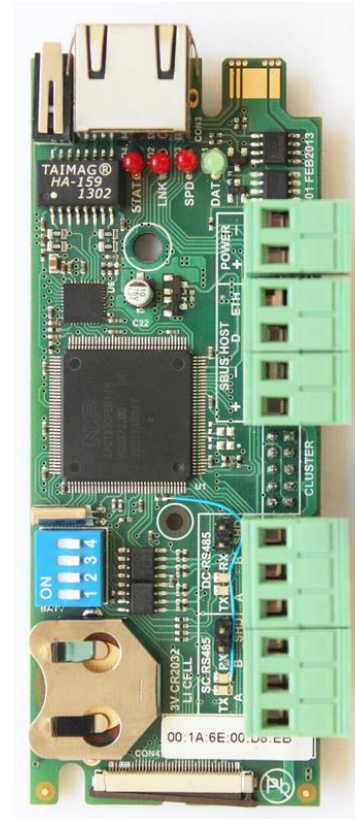

Cluster Controller **Power**

1. Input Voltage
2. Real Time Clock

INPUT VOLTAGE AND RTC

Input Voltage

12 V DC to 15 V DC, polarity sensitive

Power Requirements

Current (mA)

Power (W)

12 V DC with no peripherals?? connected

140

1.7

12 V DC with peripherals, max continuous

640

7.7

Real Time Clock (RTC) Backup

Battery

Battery Type

1 x 3V, CR2032, Lithium cell Battery

Battery Life

1 Year with Power OFF

5 Years with Power ON

5 Years storage with battery TAB in place

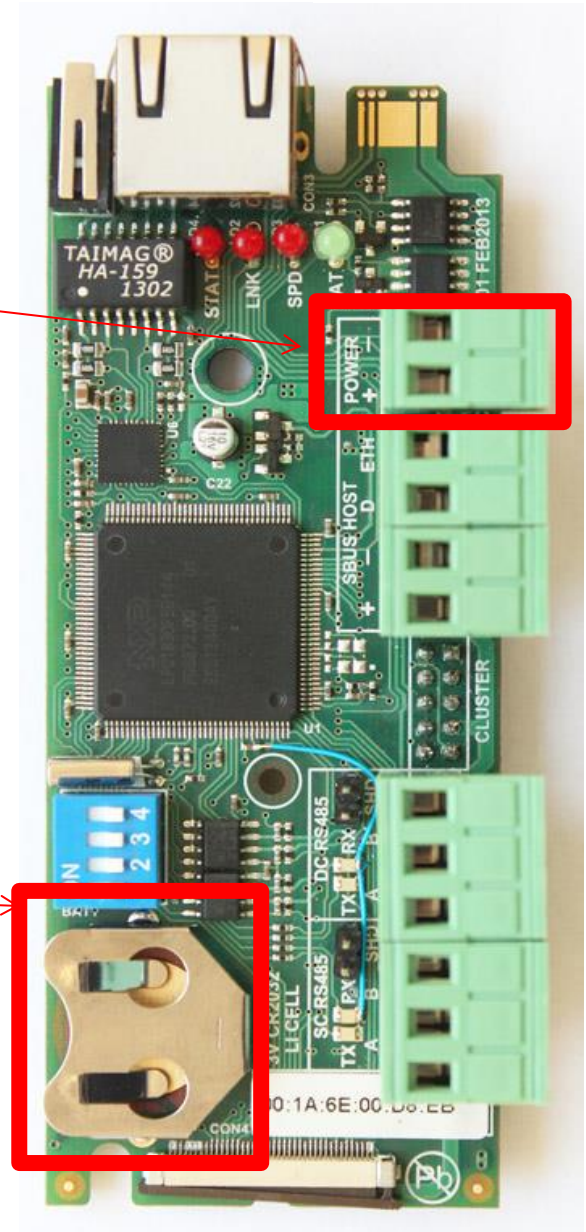

Remove Battery Tag before connecting power

Cluster Controller **Communication Ports**

1. Ethernet
2. RS485 System Controller Port
3. RS485 Door Controller Port
4. Cluster Communications
5. S-Bus Host Port

Communications Ports

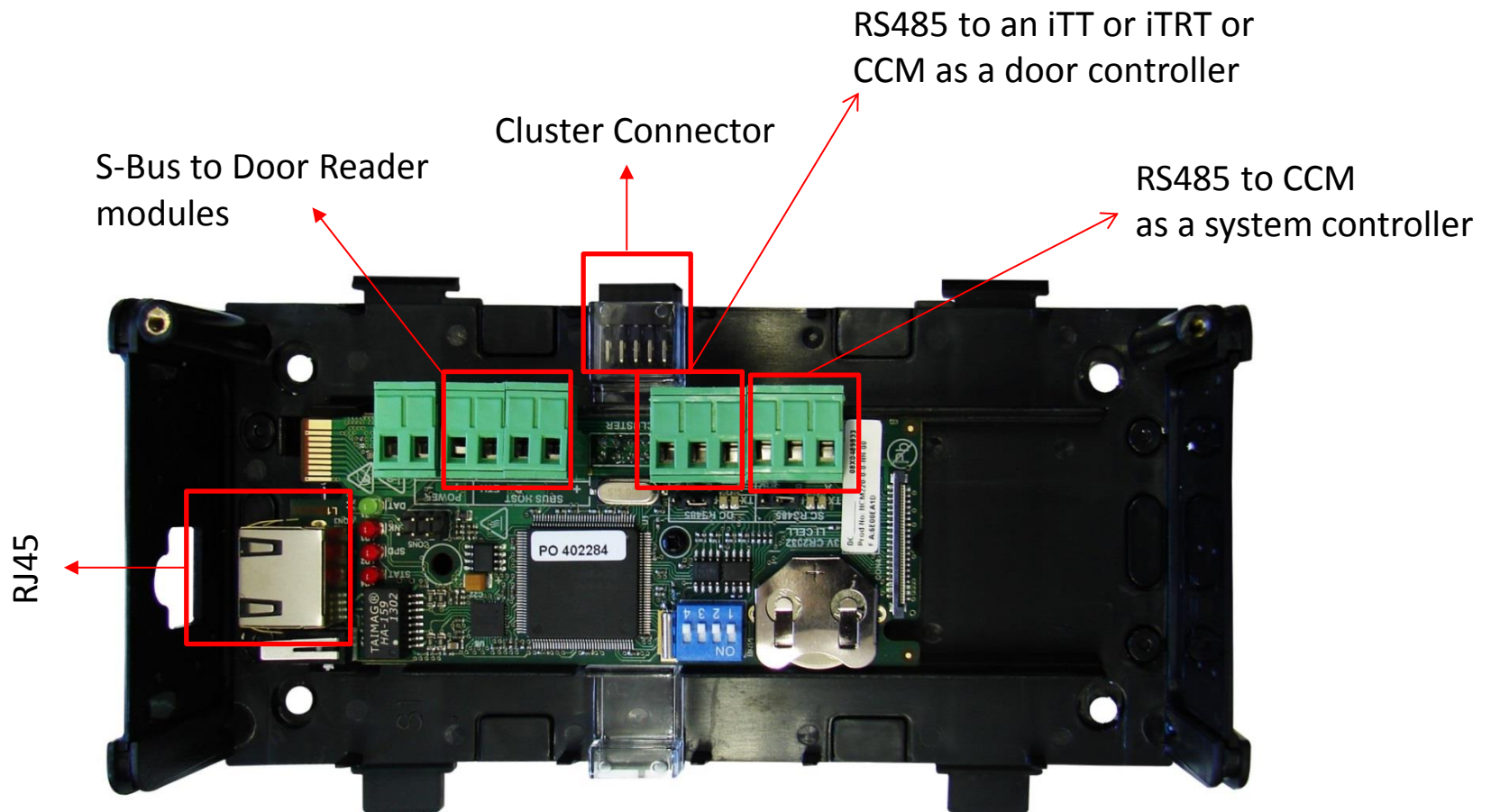

Cluster Controller **General Indicators**

1. Status LED
2. Ethernet LED
3. RS485 (SC and DC) Port indicators
4. Data LED

General Indicators

Status LED

Power On : Continuous Red.
Communications Failure : Intermittent Flashing Red
Cluster Controller Fault : Continuous flashing Red

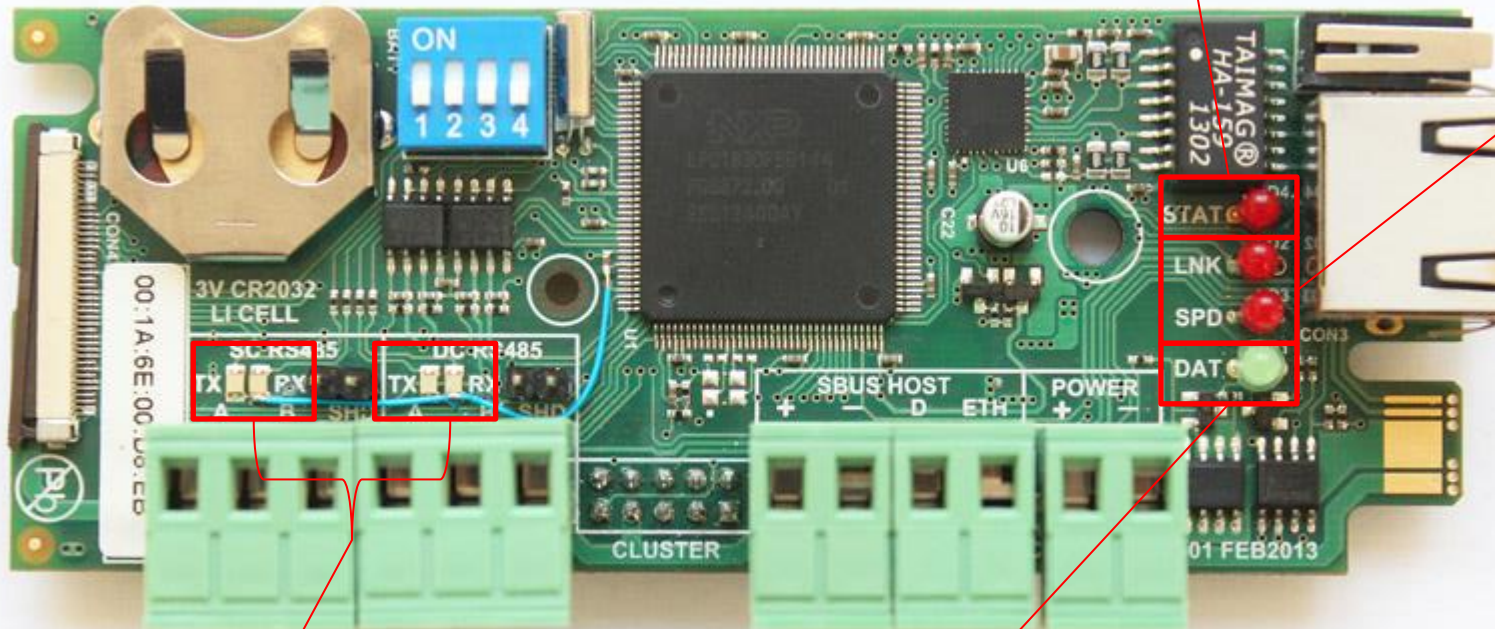

Ethernet LED

LINK LED : Continuous Red with Ethernet Connected.

SPD LED : Red LED ON for 100 MHz, OFF for 10 MHz

RS485 (SC and DC) Port Indicators

RX : Green on while receiving data
TX : Red on while sending data

Data LED

Green LED ON or flashing during any communication (Ethernet, RS485, Cluster or S-Bus)

Communication Considerations (Jumper Links)

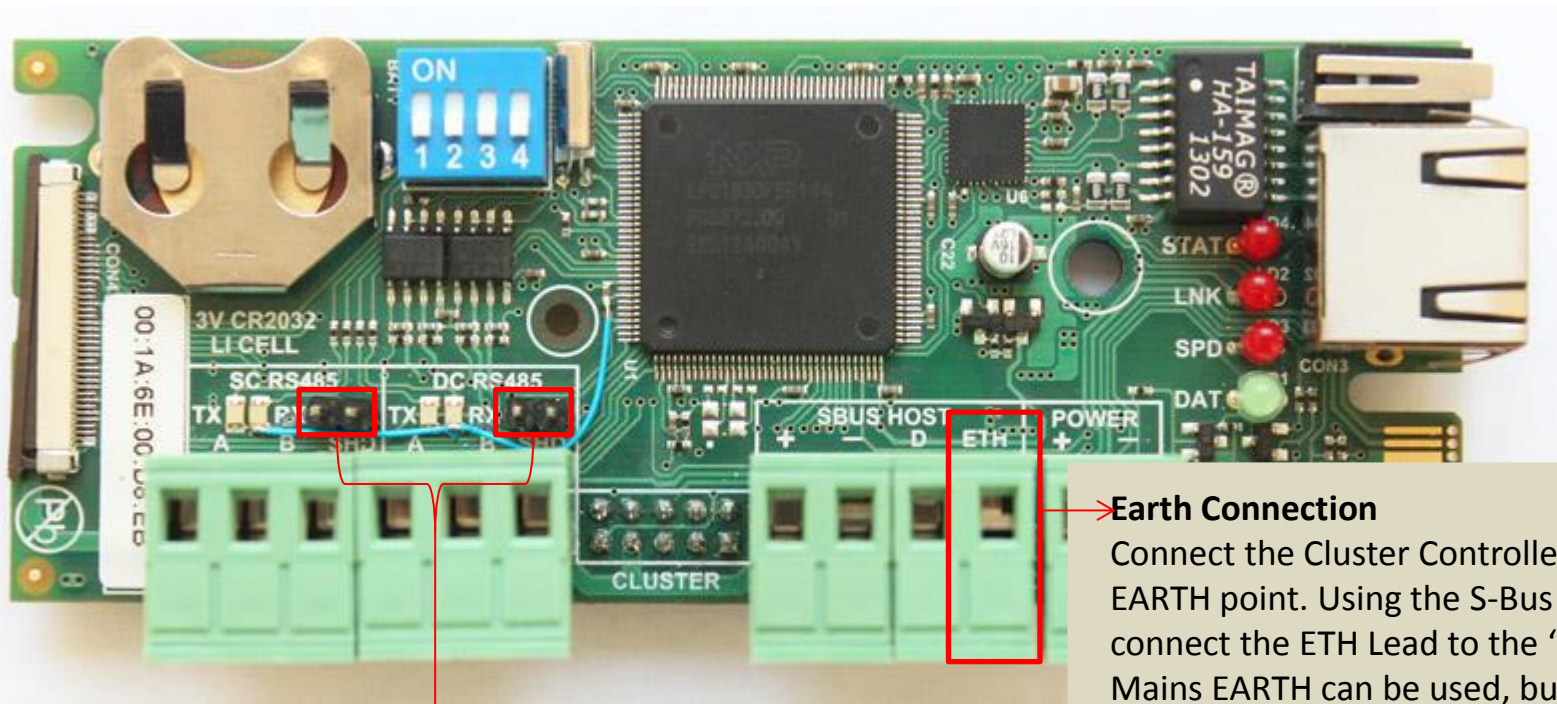

Earth Connection

Connect the Cluster Controller to a good EARTH point. Using the S-Bus Host Port, connect the ETH Lead to the 'ETH' Terminal. Mains EARTH can be used, but electrical noise may exist

Line Termination Indicators

Long RS485 transmission lines or multiple "star" RS485 connections, may cause communication problems. Placing a Jumper Link across the jumper in the LAST UNIT AT THE END OF THE CABLE RUN should solve the problem.

Cluster Controller Communication Considerations (Jumper Links)

1. Earth Connection
2. Line Termination Indicators

CONNECTING EXPANSION MODULES

1. Clustering
2. S-Bus

BENEFITS OF CLUSTERING

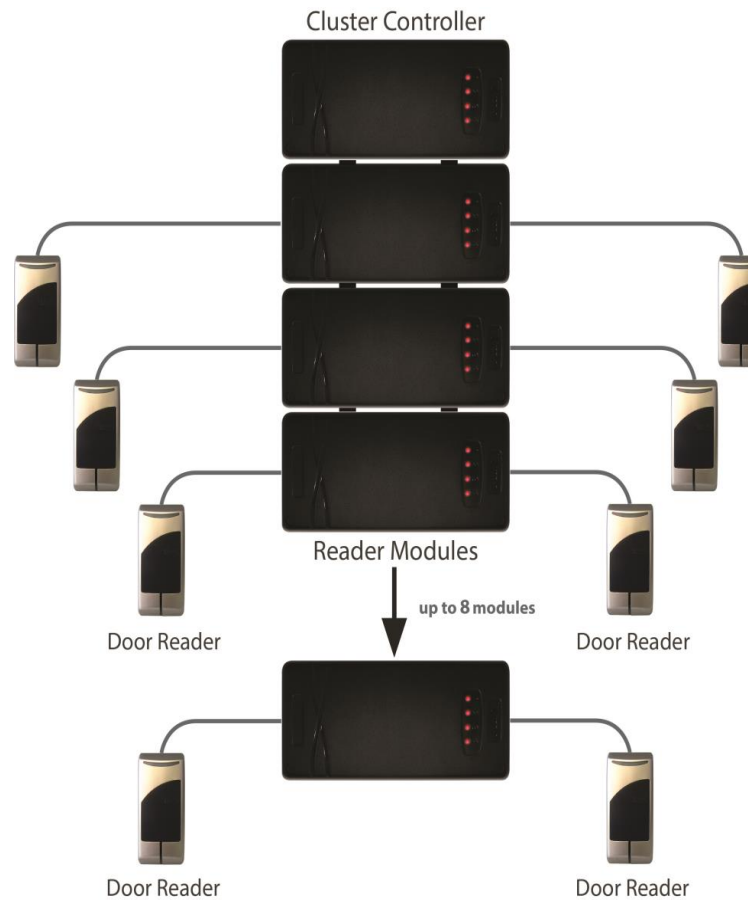

WHY USE S-BUS

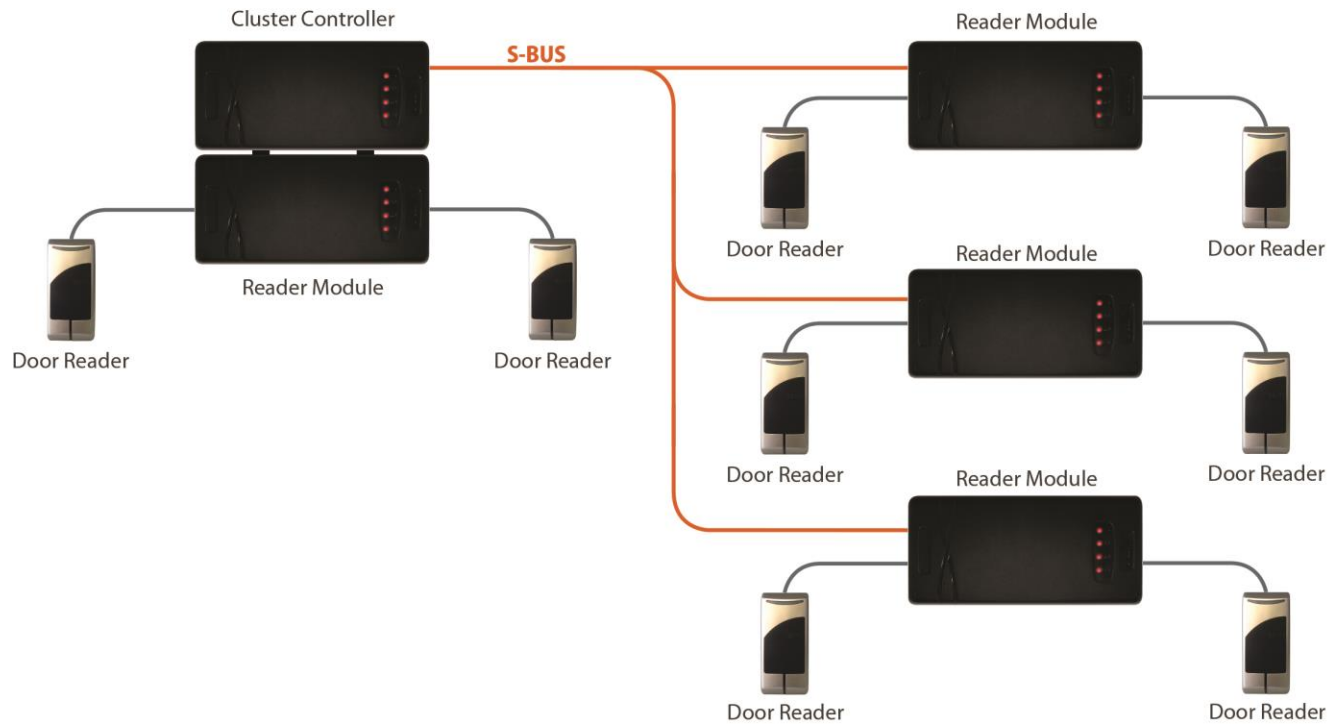

Cluster Controller **Operating Modes**

1. Access Portal LITE Mode

DOOR Controller Mode



Downstream Components	Limits	Fixed Addresses
Clustered Expansion Modules	Cluster power rail supports up to 8 Modules	Up to 16
S-Bus-coupled Devices	S-Bus limit of 8 Addresses	Up to 8

TOTAL Maximum: 24 Fixed Addresses

Access Portal LITE Mode



This mode allows for a Cluster Controller Module to function as a stand-alone controller for maximum of 16 Fixed addresses. The user will be able to manage and configure the system on any (HTML 5 Compliant) browser via the Ethernet Port, using the embedded web application within the Cluster Controller. (AP LITE Mode **does NOT support** IP communications with other modules, such as Door Controllers, or the legacy iTRT.)

Downstream Components	Limits	Fixed Addresses
Clustered Expansion Modules	Cluster power rail supports up to 8 Modules	Up to 16
S-Bus-coupled Devices	S-Bus limit of 8 Addresses	Up to 8
DC RS485: Door Controllers (with their Expansion Modules and all their attached S-Bus Devices)	Limited by the number of Fixed Addresses remaining from a Quota of 16	Whatever remains from 16

TOTAL Maximum: 16 Fixed Addresses

CLUSTER CONTROLLER **DIP Switch Settings**

1. **Factory Default**
2. **Door Controller Mode**
3. **Access Portal LITE Mode**

FACTORY DEFAULT

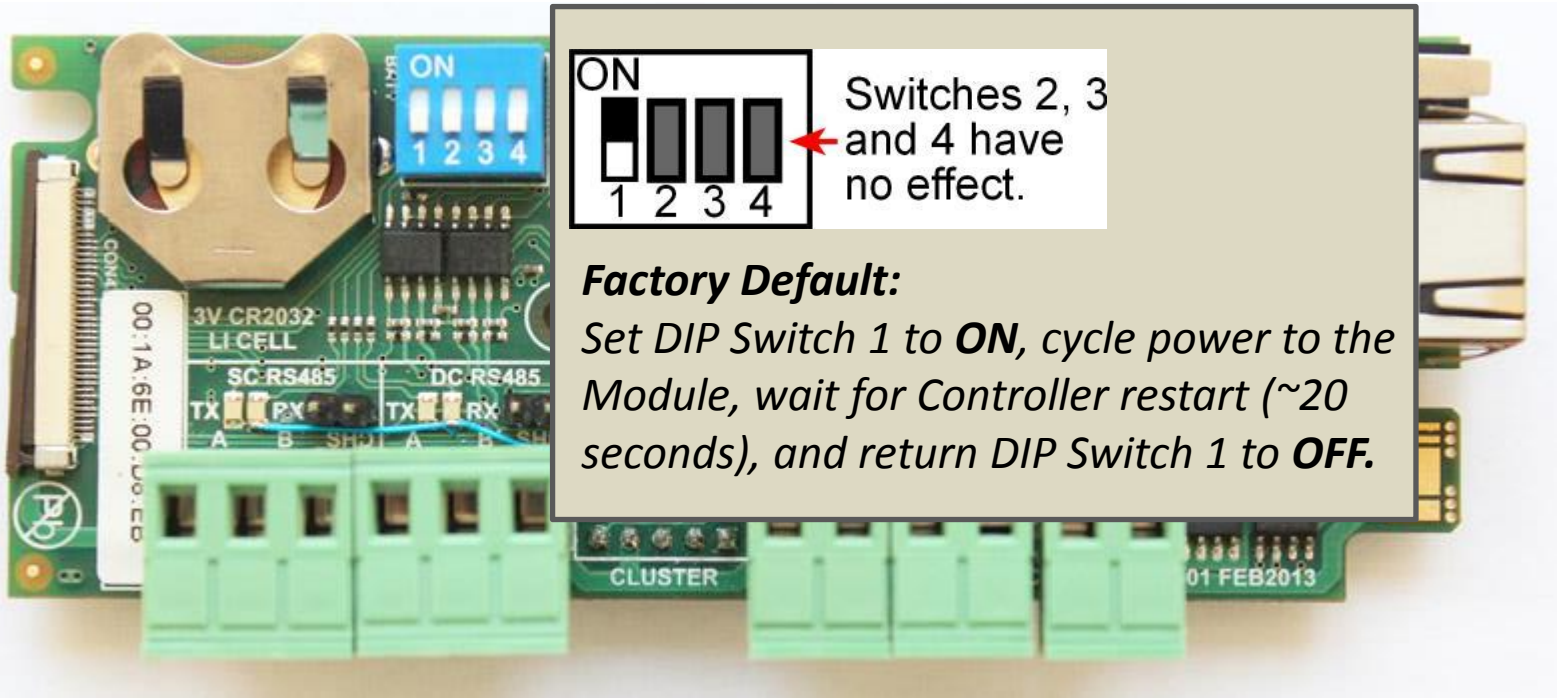

ACCESS PORTAL LITE Mode

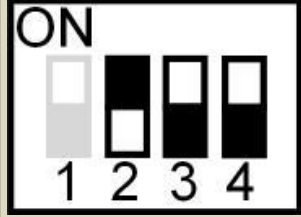
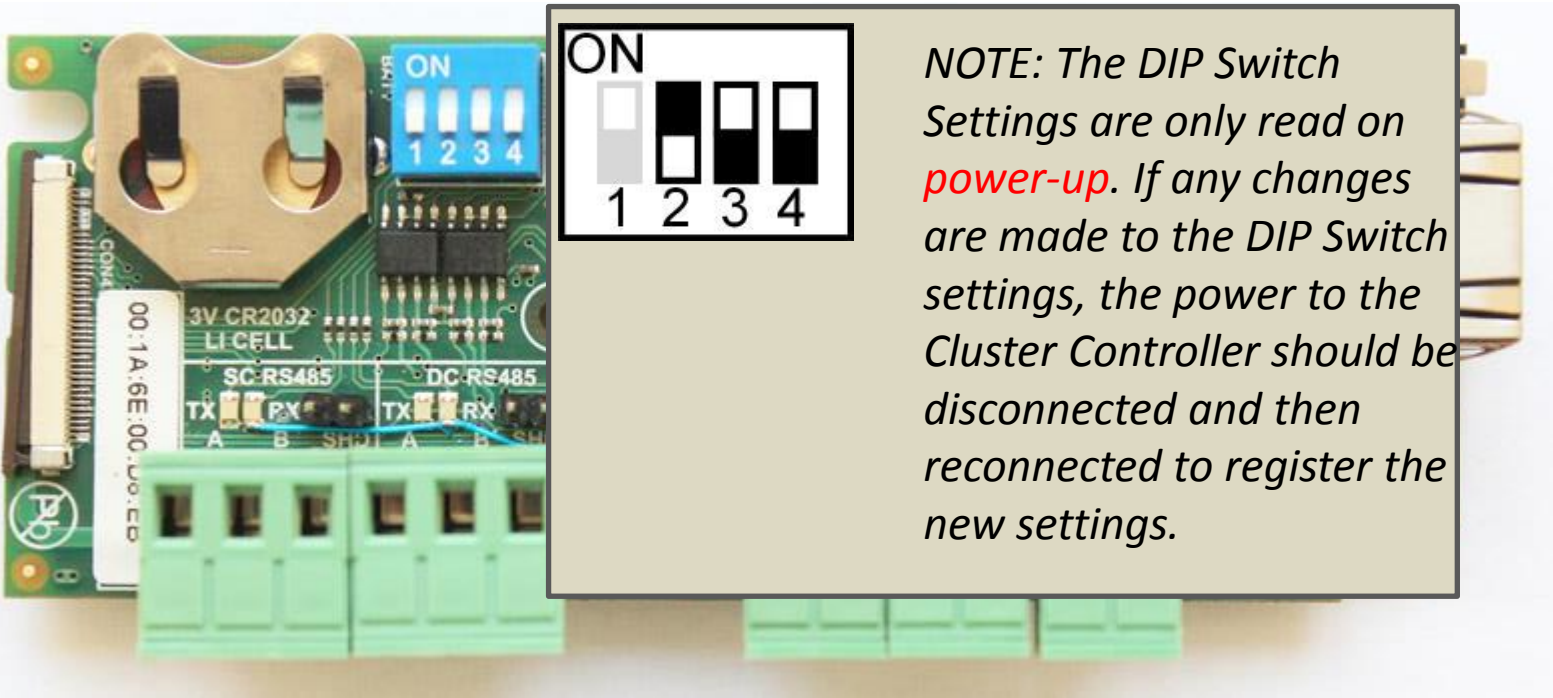

*NOTE: The DIP Switch Settings are only read on **power-up**. If any changes are made to the DIP Switch settings, the power to the Cluster Controller should be disconnected and then reconnected to register the new settings.*

DOOR CONTROLLER Mode

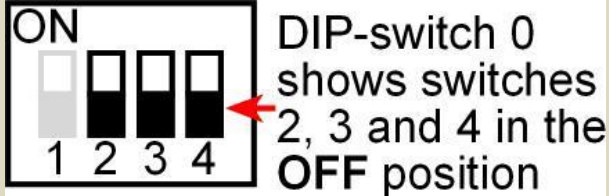
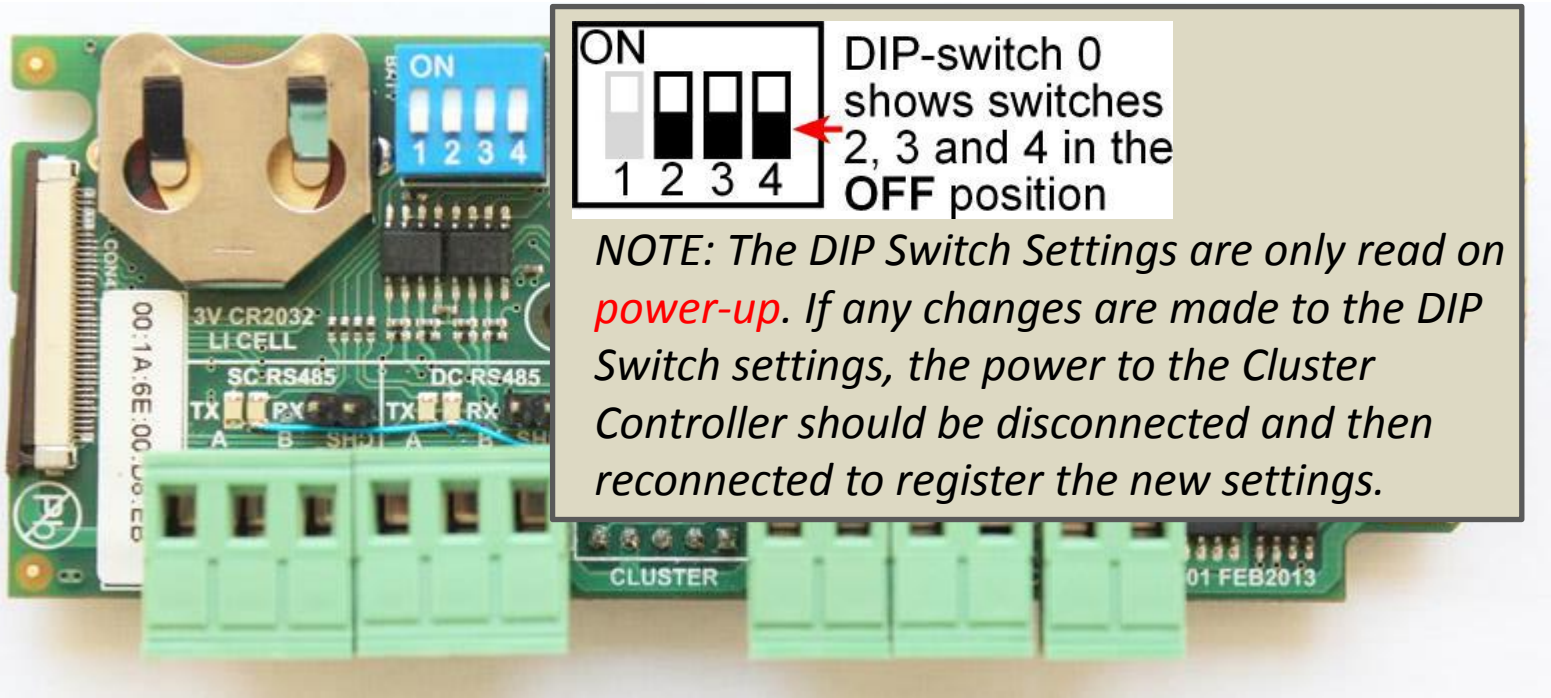

*NOTE: The DIP Switch Settings are only read on **power-up**. If any changes are made to the DIP Switch settings, the power to the Cluster Controller should be disconnected and then reconnected to register the new settings.*

WIEGAND READER MODULE

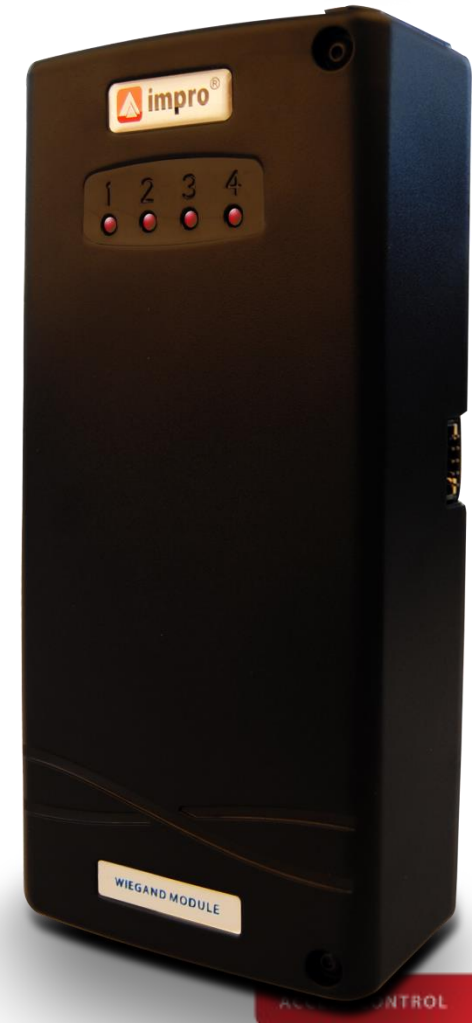
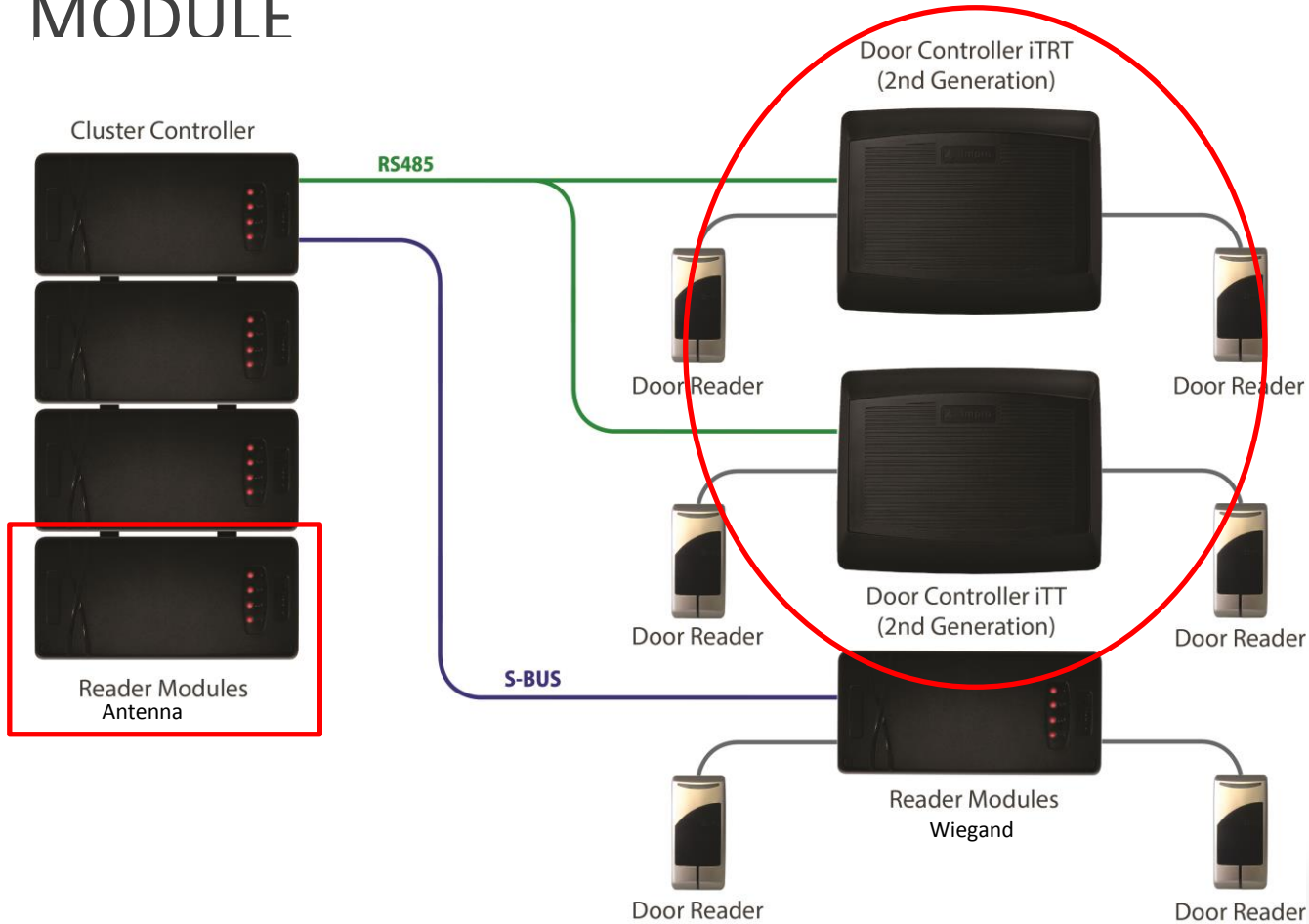

Features



- Supported in **Access Portal LITE, PRO** and **ENTERPRISE** solutions
- Completely modular design for ultimate in-field configuration flexibility
- Industry first true plug & play hardware expansion
- Backwards compatible with Impro iTT and iTRT Door Controllers
- The only Door Controller Hardware required for the site

Specifications

- Supports full offline functionality for up to **10 000** Tagholders
- Available in TCP/IP & RS485 or RS485 only options
- Compatible with both Cluster Controller & Antenna Reader Modules



NEW HARDWARE COMPONENTS

WIEGAND READER MODULE

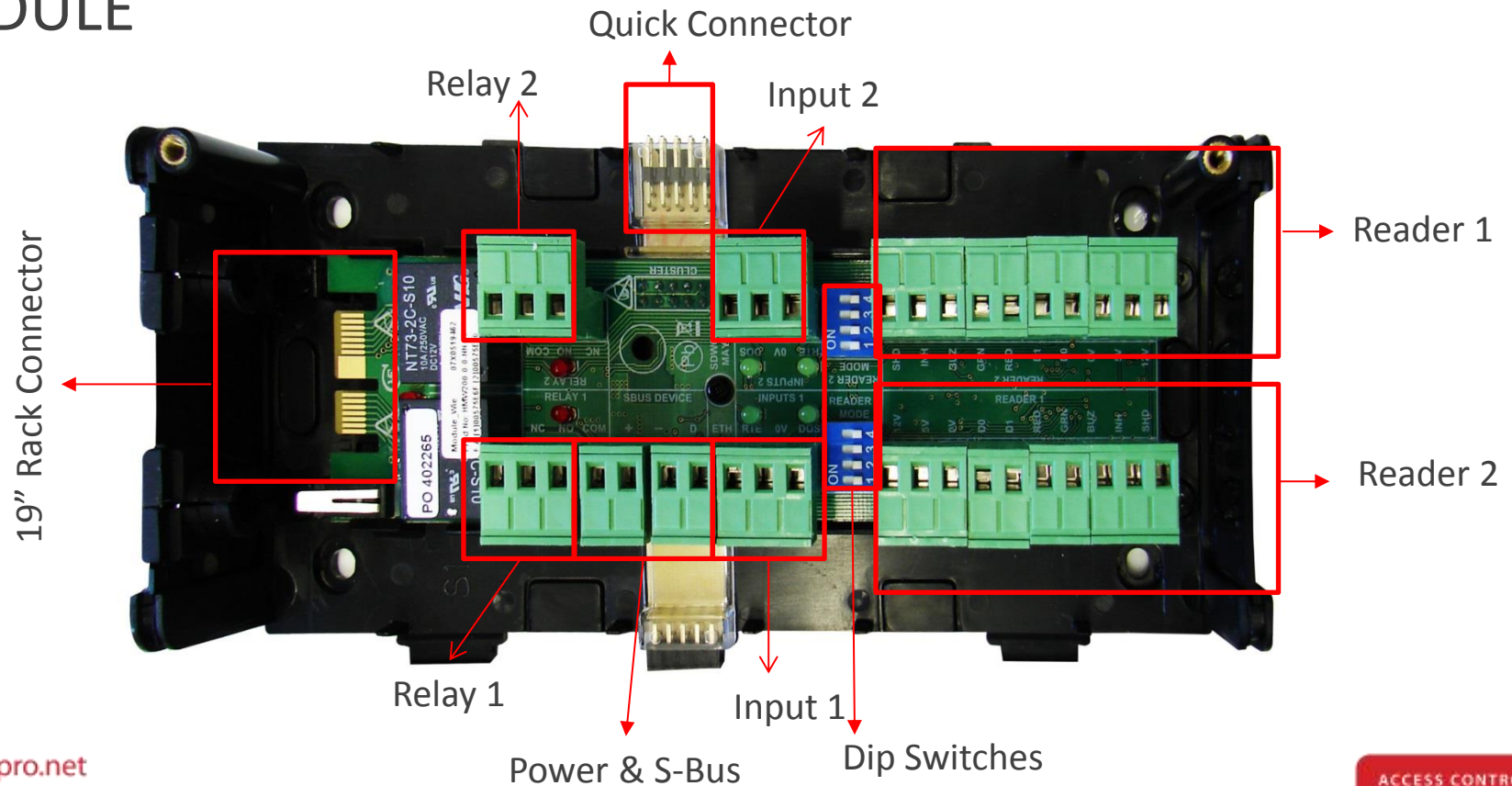

WIEGAND READER BASIC ARCHITECTURE

- Connects directly to Cluster Controller via
 - Quick-Connectors
 - S-Bus (150m between Cluster Controller & Reader Modules)
- Connects directly to additional Wiegand Reader Modules or Antenna Reader Modules or Cluster Controllers via
 - Quick-Connectors
 - S-Bus (150m between Cluster Controller & additional Reader Modules)

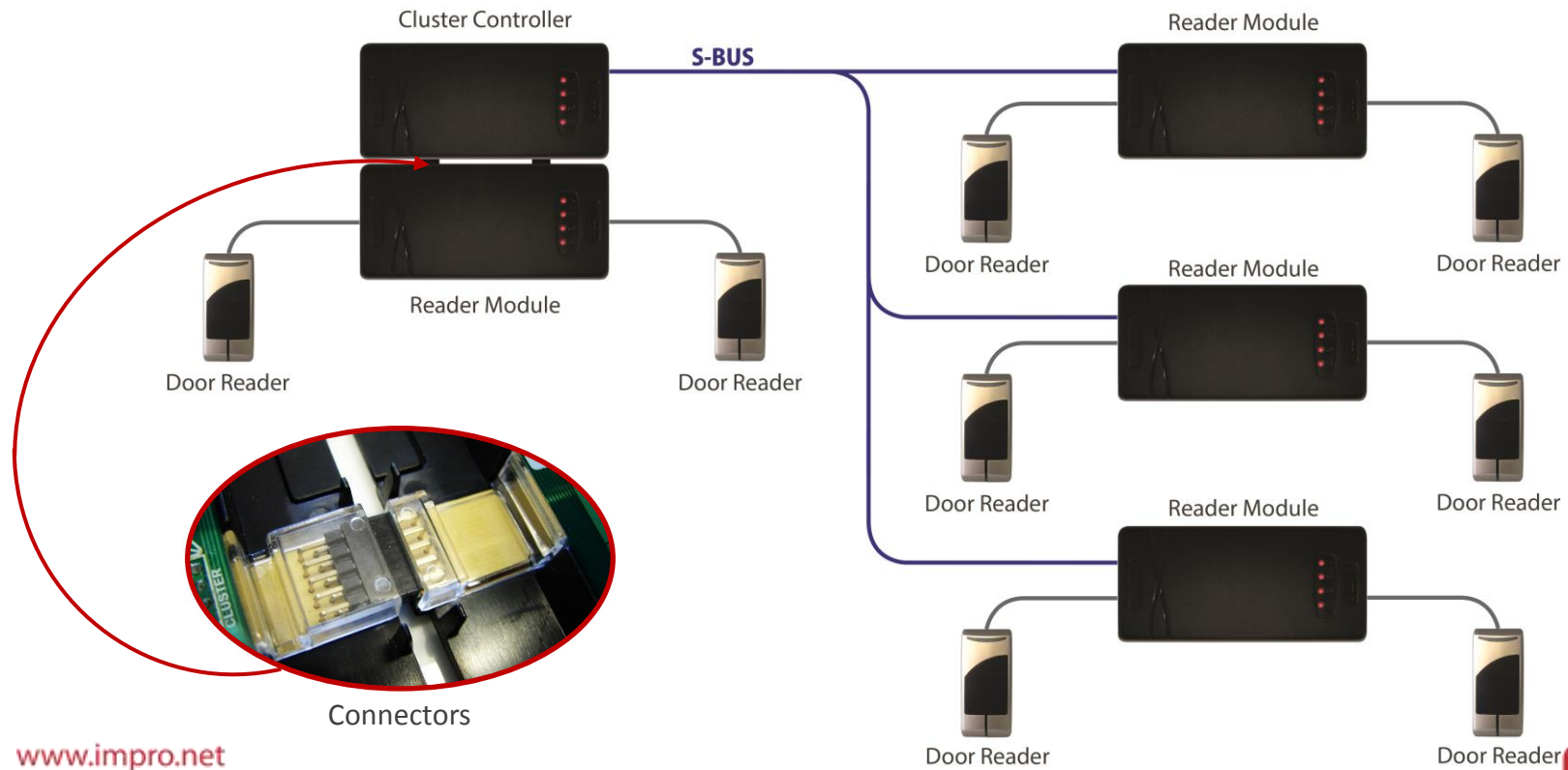

Connecting to a Clustered Wiegand Reader Module

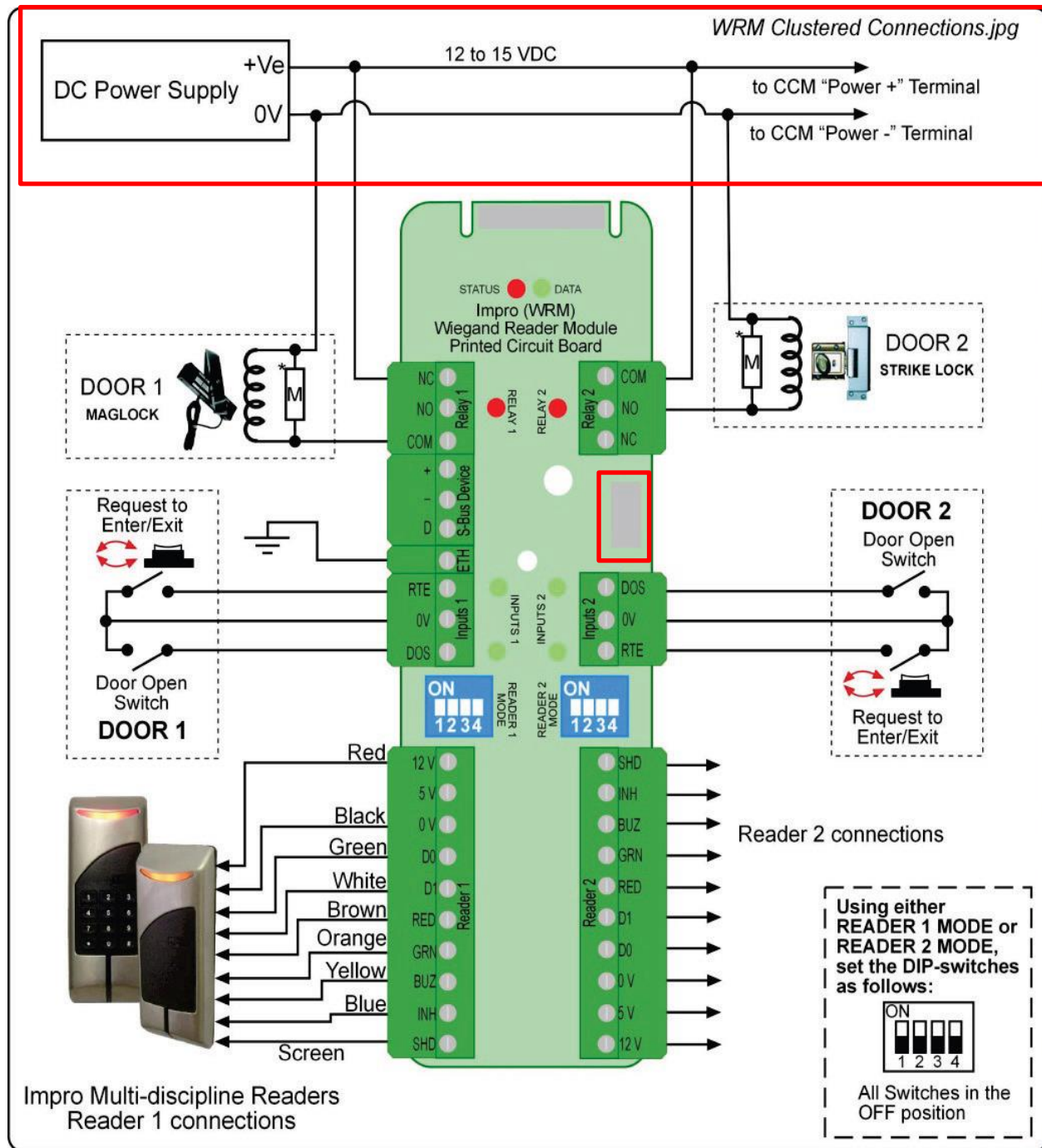

Connecting to a Remotely Mounted Wiegand Reader Module

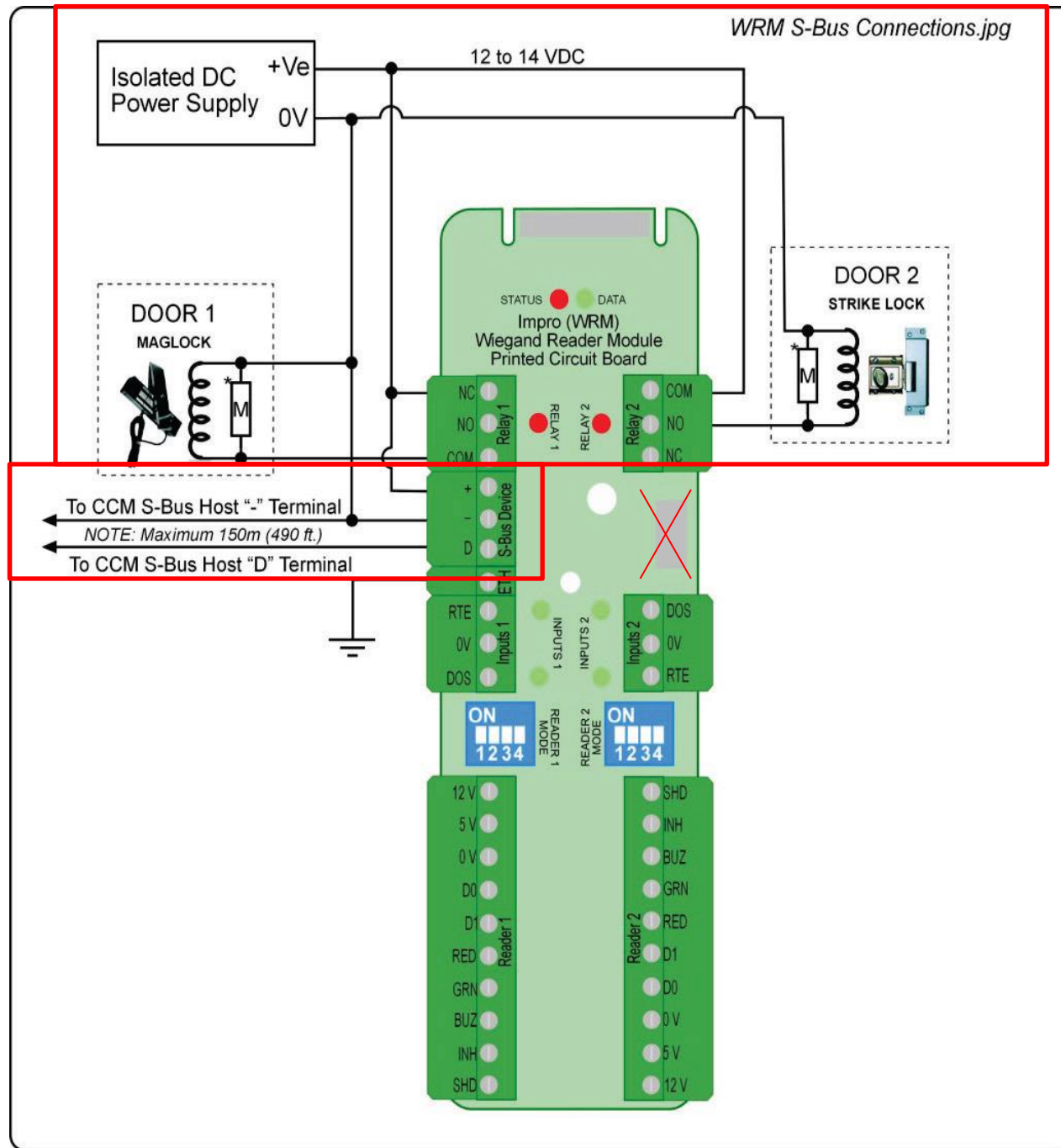

ANTENNA READER MODULE

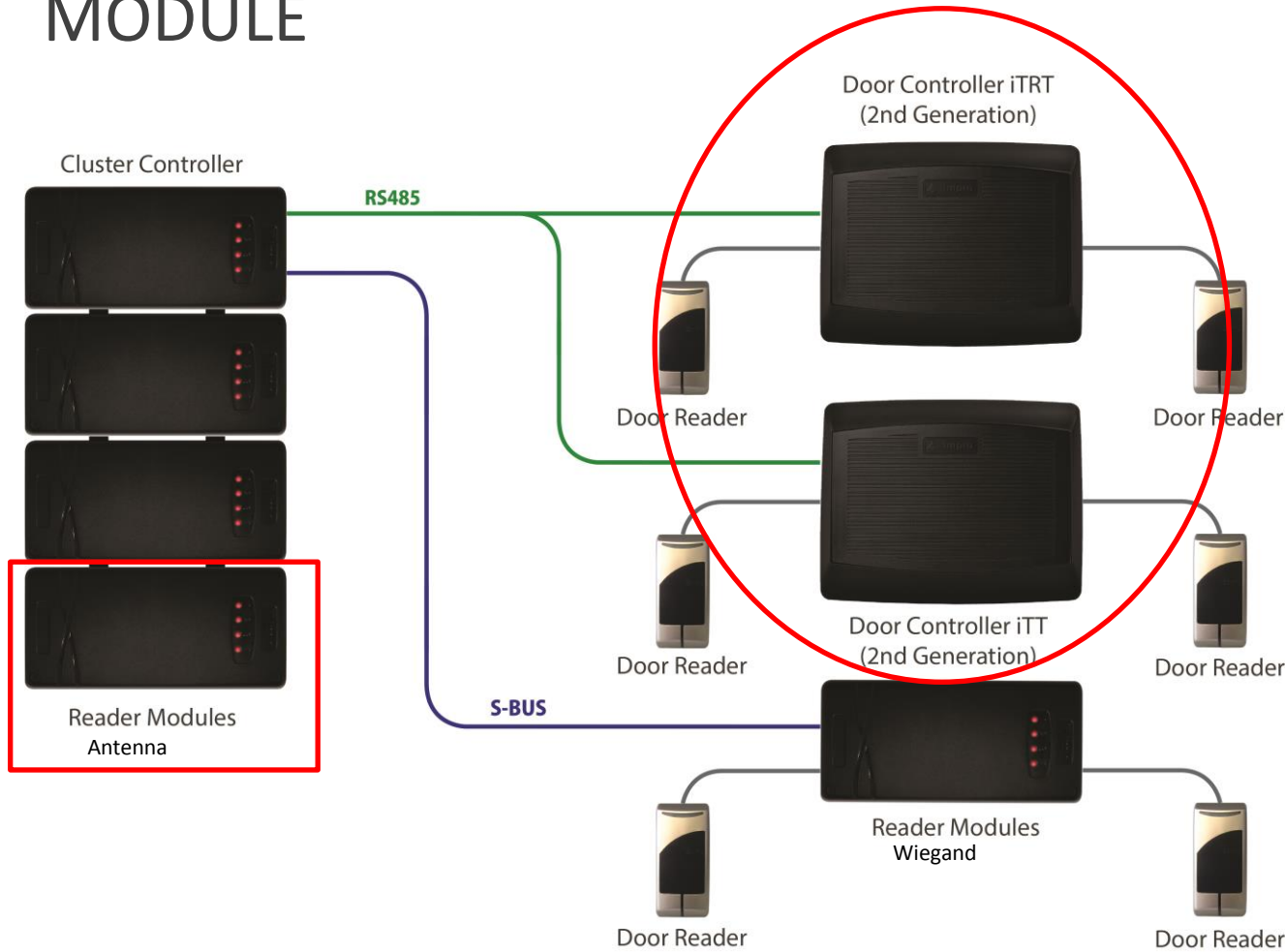

Features

- Supported in **Access Portal LITE, PRO** and **ENTERPRISE** solutions
- Completely modular design for ultimate in-field configuration flexibility
- Industry first true plug & play hardware expansion
- Backwards compatible with Impro iTT and iTRT Door Controllers
- The only Door Controller Hardware required for the site



Specifications

- Supports full offline functionality for up to **10 000** tag holders
- Supports up to **100 000** buffered transactions per Cluster Controller
- Available in TCP/IP & RS485 or RS485 only options
- Compatible with both Cluster Controller & Wiegand Reader Modules



NEW HARDWARE COMPONENTS

ANTENNA READER MODULE

Connector for rack mount option

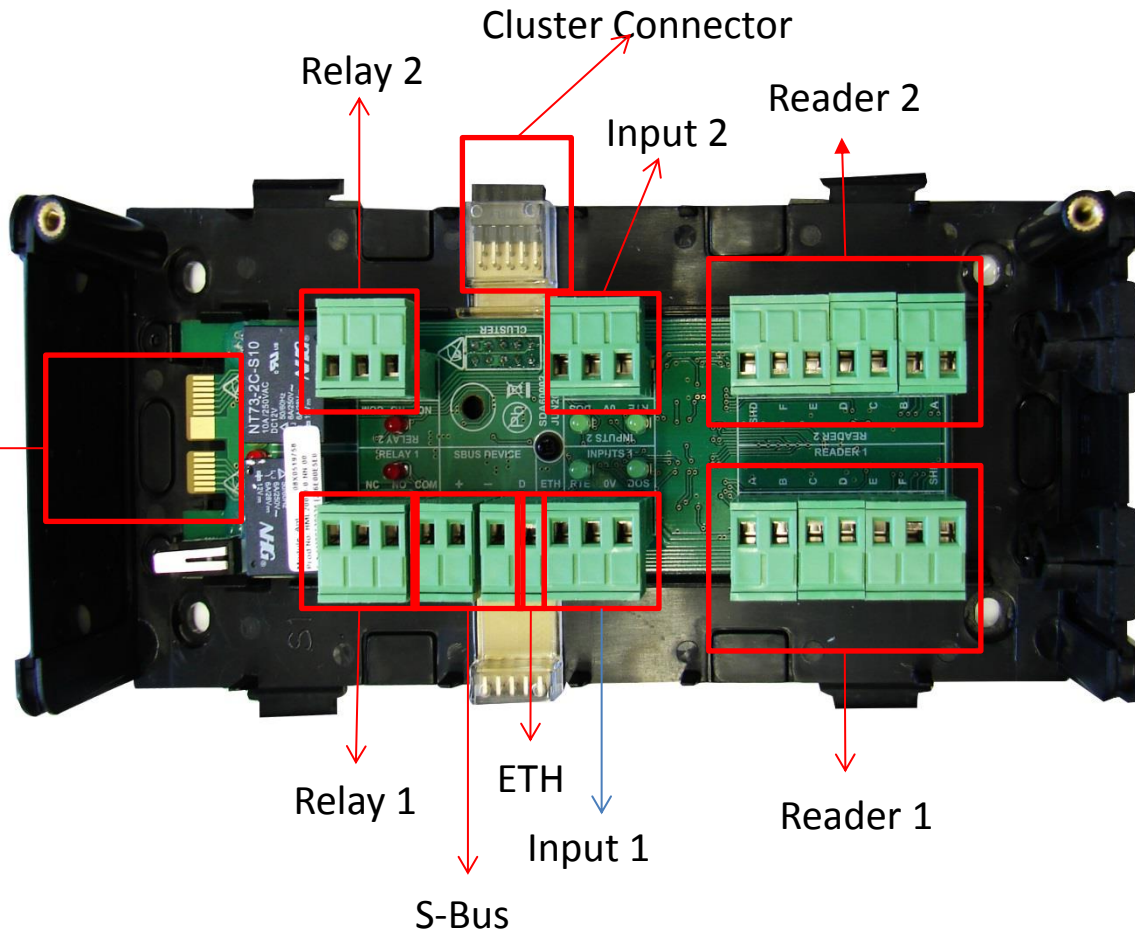

ANTENNA READER BASIC ARCHITECTURE

- Connects directly to Cluster Controller via
 - Quick-Connectors
 - S-Bus (150m between Cluster Controller & Reader Modules)
- Connects directly to additional Antenna Reader Modules or Wiegand Reader Modules or Cluster Controllers via
 - Quick-Connectors
 - S-Bus (150m between Cluster Controller & additional Reader Modules)

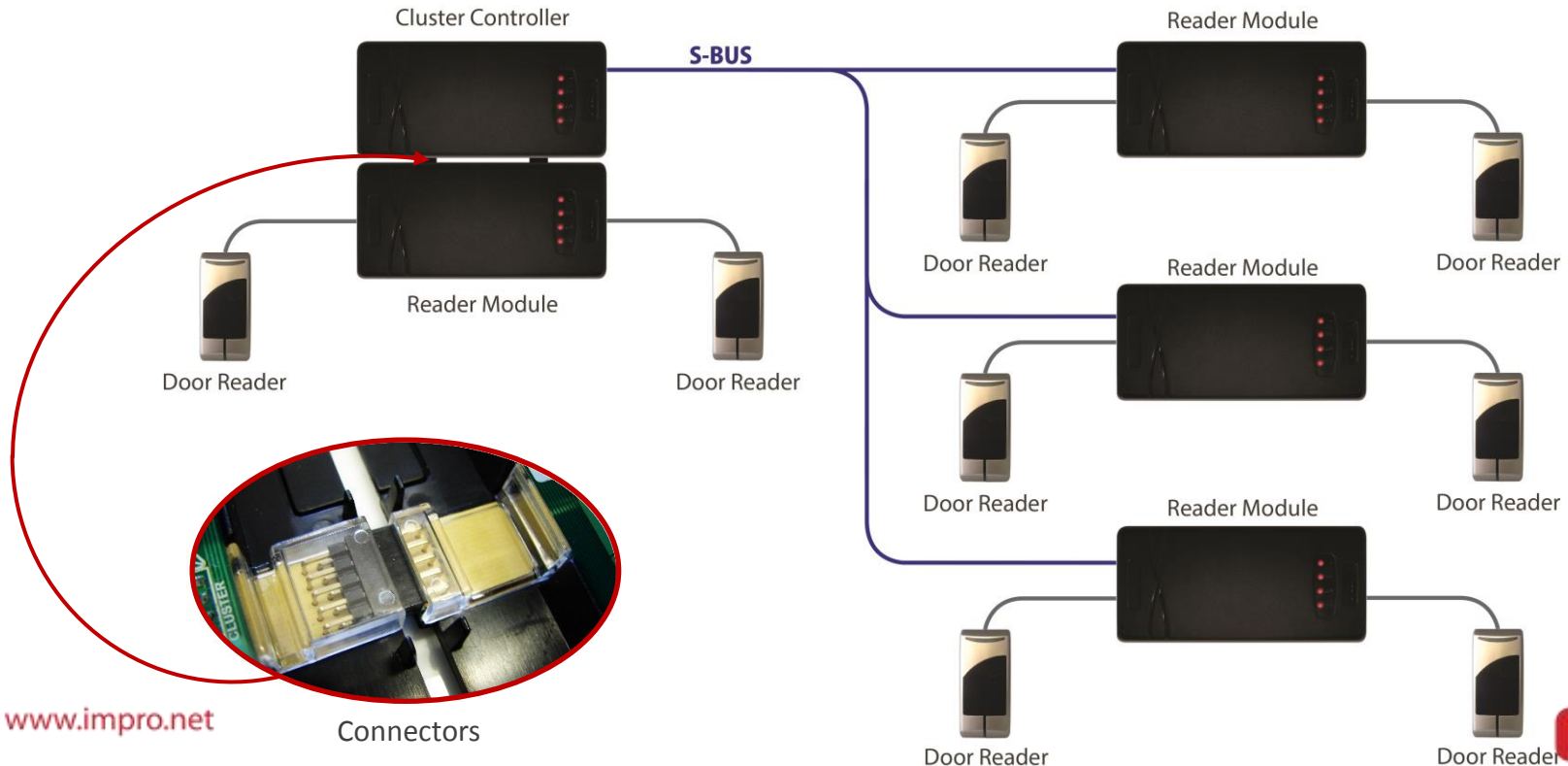

Connecting to a Clustered Antenna Reader Module

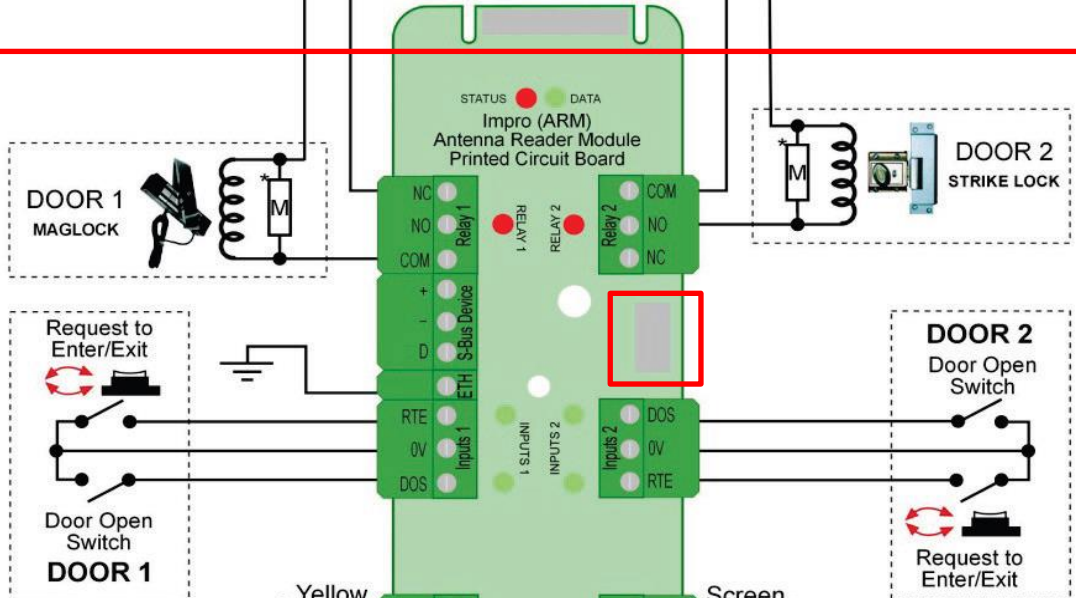
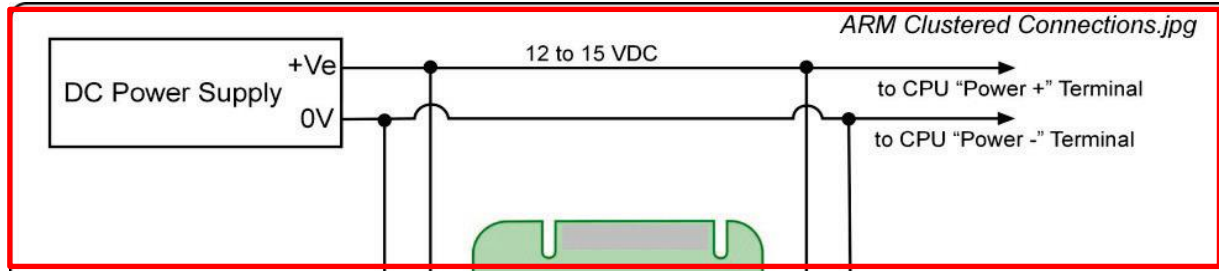

Impro 125 kHz Antenna Reader Range Reader 1 connections

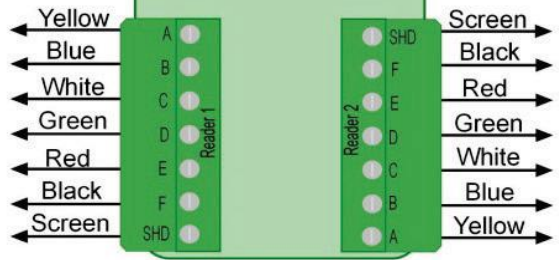

Impro 125 kHz Antenna Reader Range Reader 2 connections



Connecting to a Remotely Mounted Antenna Reader Module

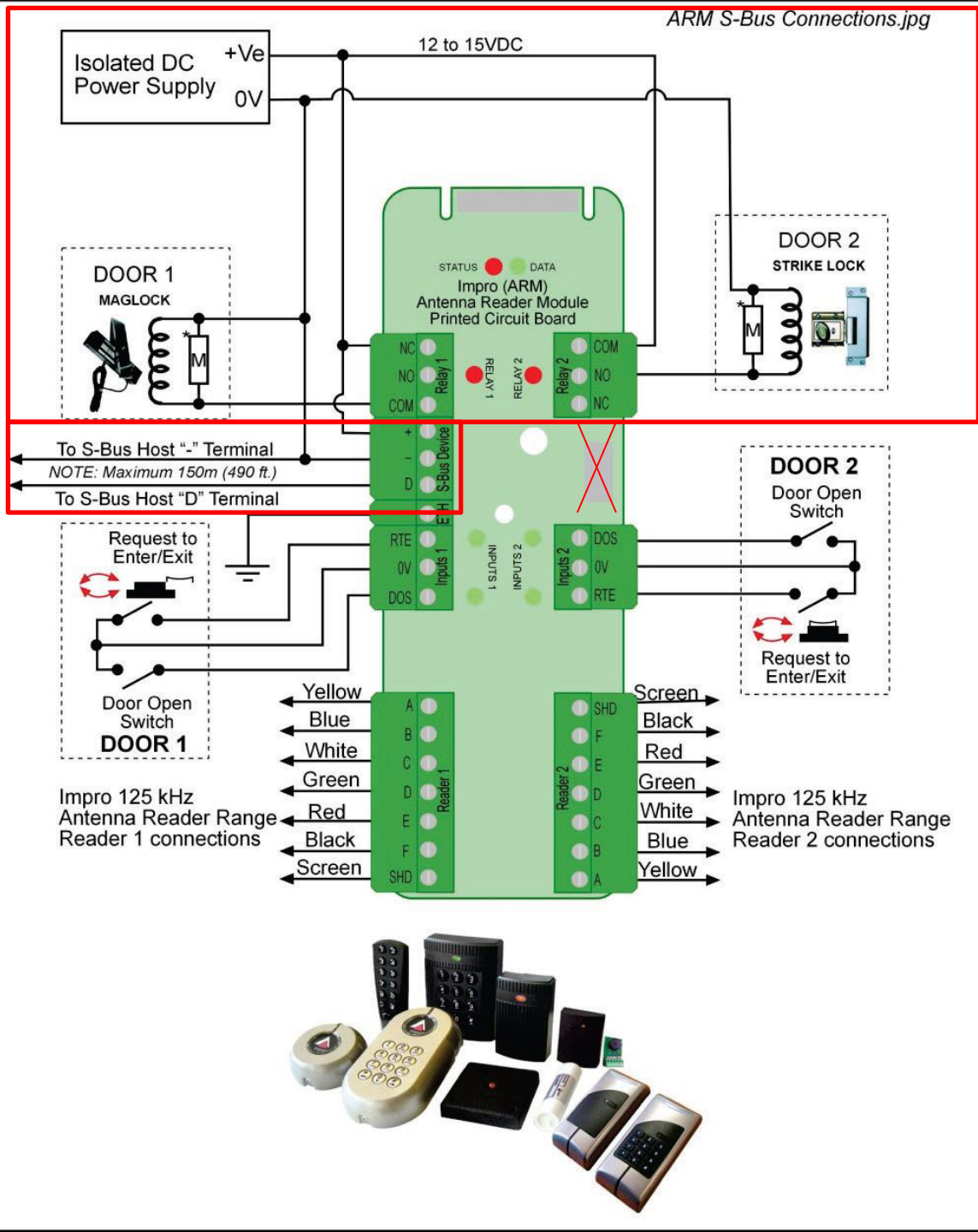

4. CONFIGURATION **Options**

1. Option ONE
2. Option TWO
3. Option THREE
4. Option FOUR

ACCESS PORTAL LITE

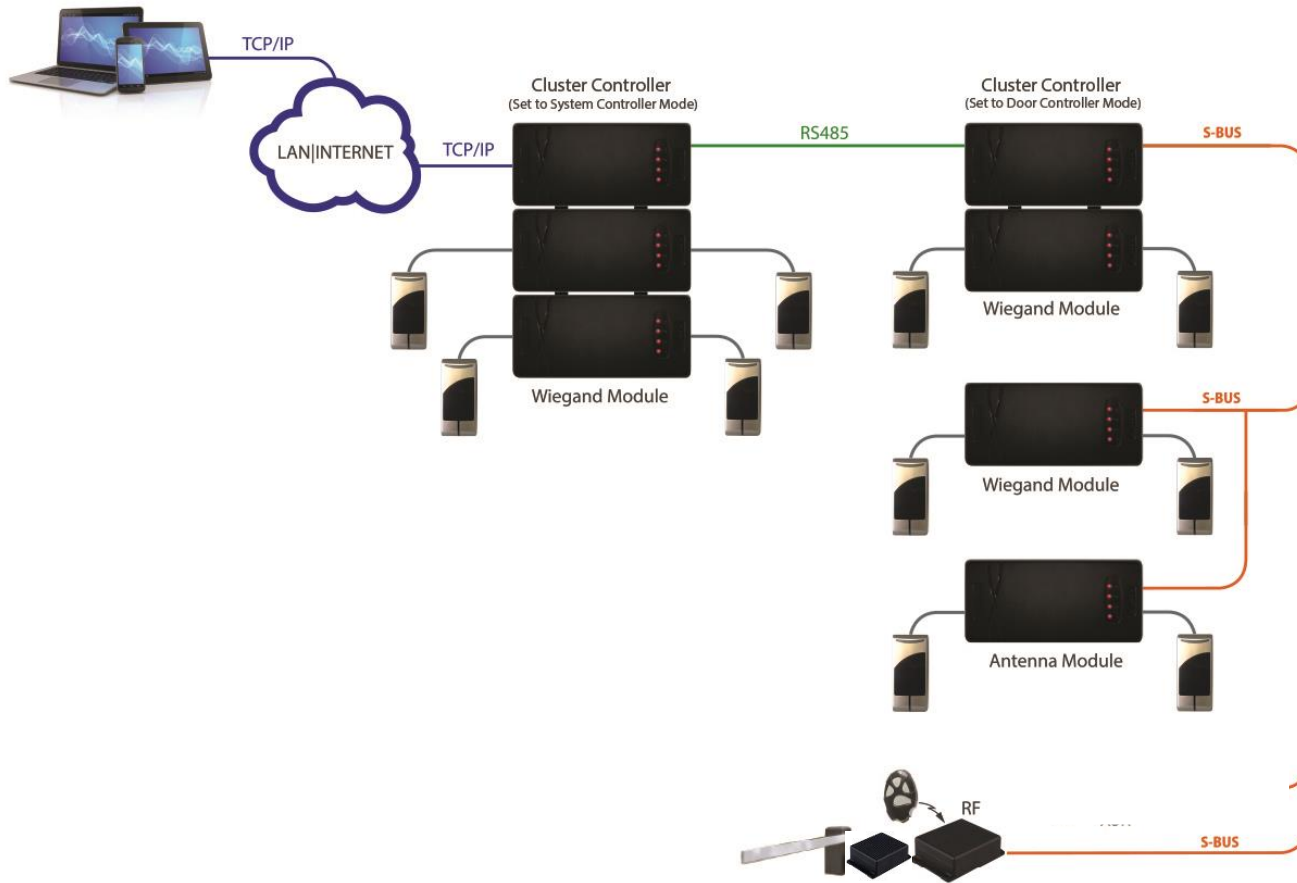

CONFIGURATION OPTION – ONE

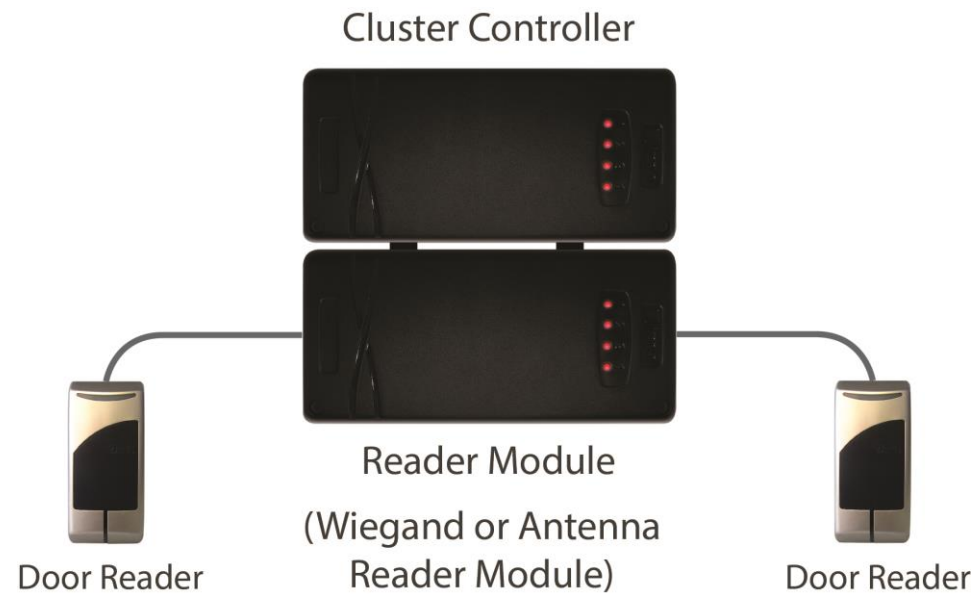

Clustering

CONFIGURATION OPTION – TWO

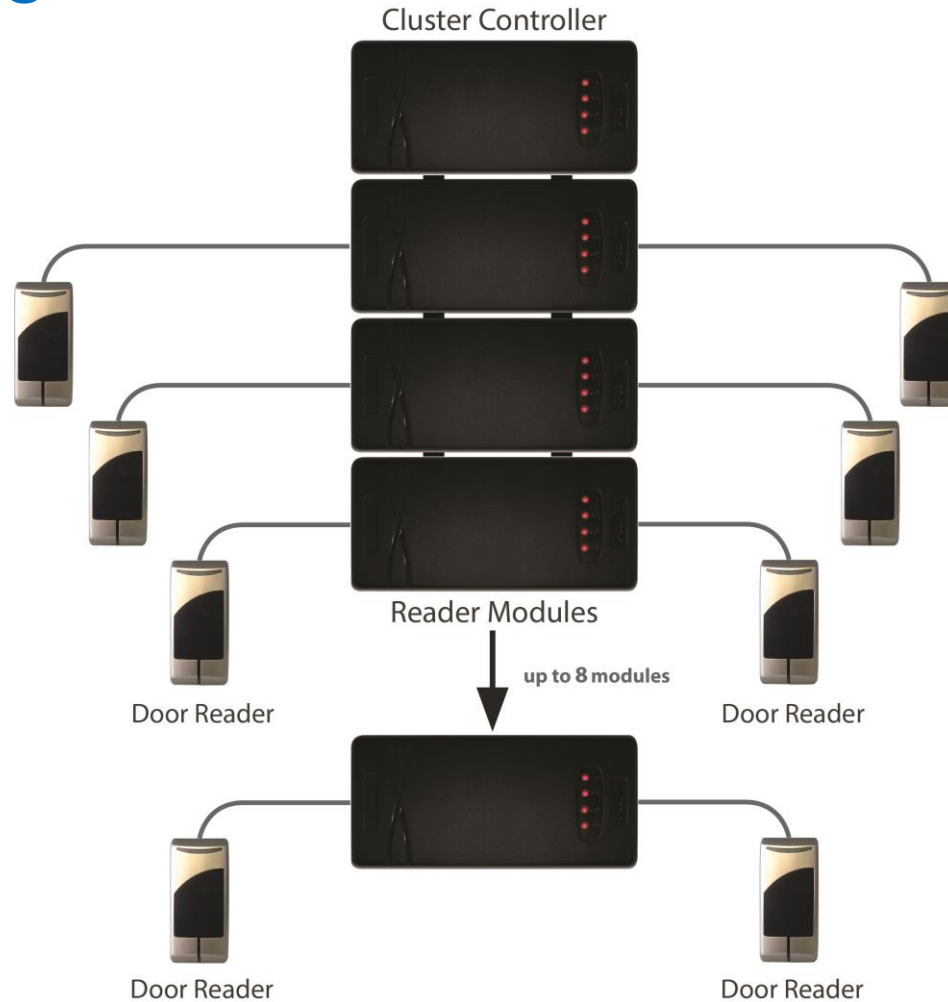

Clustering

CONFIGURATION OPTION – THREE

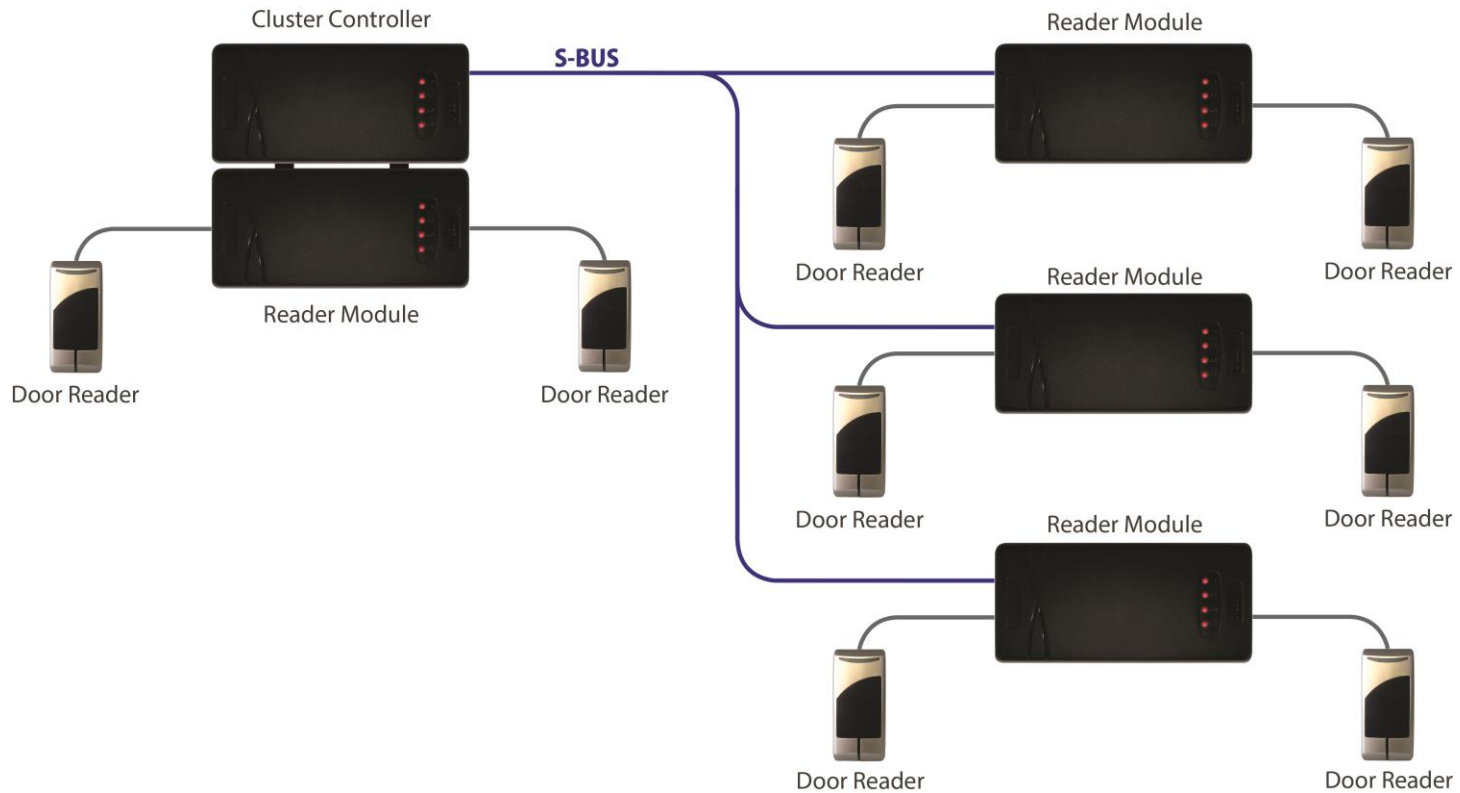

Clustering + S-Bus

CONFIGURATION OPTION – FOUR

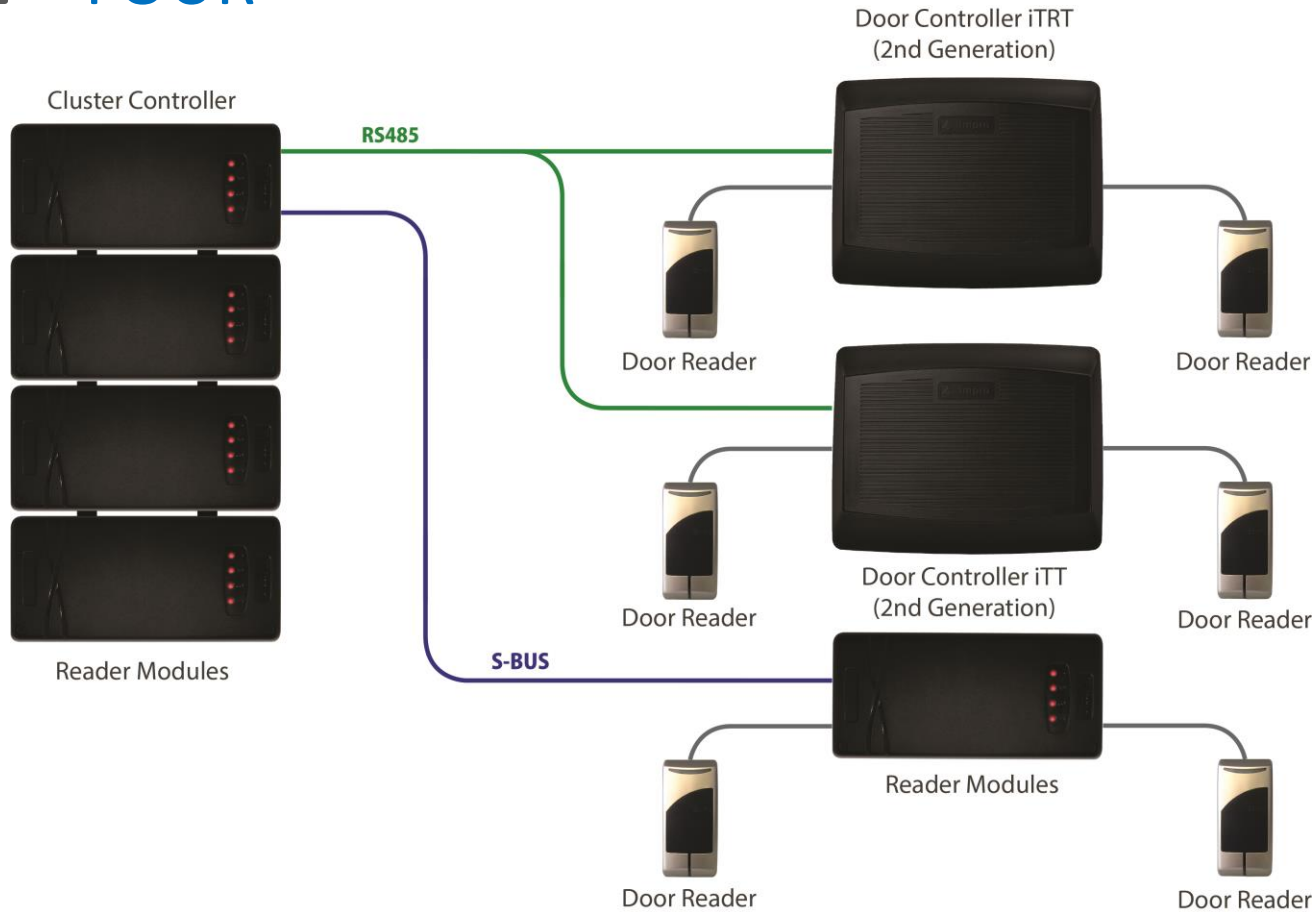

Clustering + S-Bus to new Reader Modules + 2nd Generation Door Controllers

CONTENT

5. Access portal **LITE**

- Software Concepts
- Starting the Access Portal LITE
- **SETTINGS** menu
- **REPORTS** menu
- **TAG HOLDERS** menu
- Firmware Upgrade Utility
- Replacing a faulty Cluster Controller

Why the shift to new Technology

SOFTWARE CONCEPTS

Intelligent Design

While you multitask, it does to.
Intelligent enough to know when to do it for you & when to let you do it.

Total Control

Total control means true mobility,
instant access, everywhere you go.

Custom Reports

No matter what device you are using,
your reports will always look the same.

Seamless Scalability

You decide what you want,
when you need it, no matter how basic
or complex a site.

Simply Visual

We have made it easier than ever to
browse and manage.

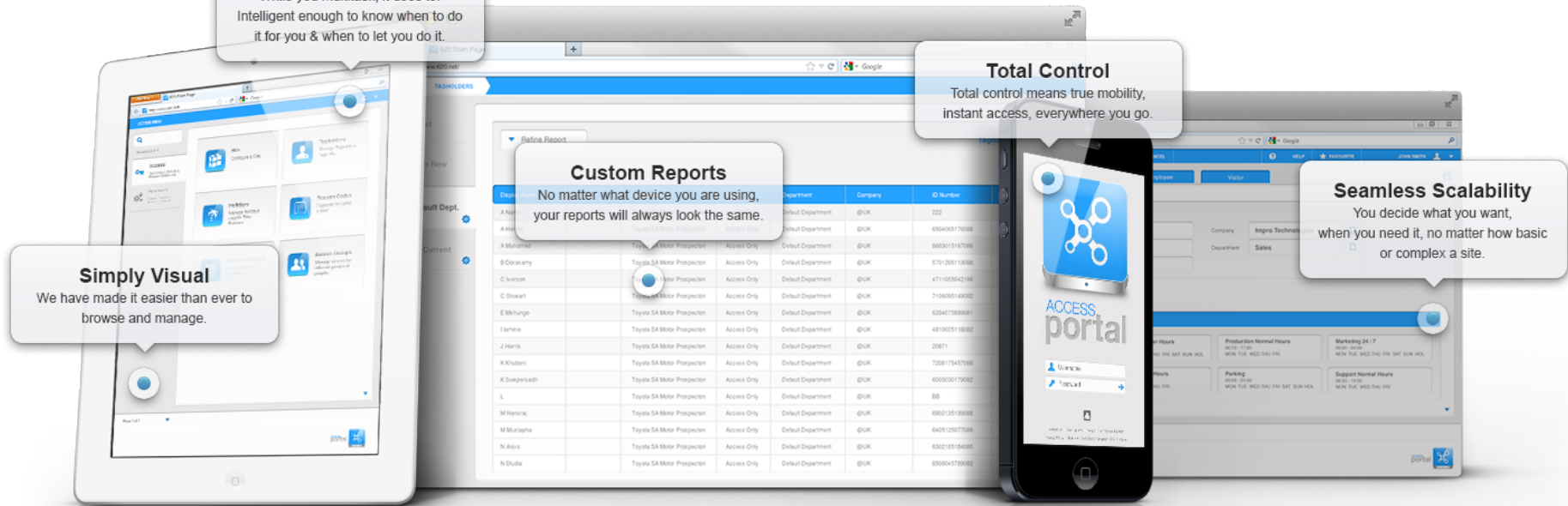

HTML5 | Google Web Toolkit (GWT) | Cascading Style Sheets (CSS)

SQLite, Express, Server, Azure | Web sockets | Hibernate | Lucene

Application programming Interface (API) | Extensible Markup Language (XML)

Before we start:

Ensure the following:

- 1 Cluster Controller Module dip switches are set for **apLite**
- The CCM that is set to apLite can have either an active Ethernet Connection, via a fixed LAN point or a wireless switch or be connected directly via the TCP/IP port to a Computer.
- Access to a HTML compliant browser

NOTE: HTML 5 compliant browsers that support web sockets :

- Chrome (30.0.1599.101)



- Internet Explorer (10)



- Firefox (24.0)



www.impro.net or later versions of these browsers

Lets start :

STEP 1

- Connect your CCM to your PC or the network
- NOTE: Remember to disconnect and reconnect the power if changes were made to the dip switches

STEP 2

- Go to your browser and type in <http://aplite/> or IP address



If the Web Server resides on a Port other than Port 80, the URL becomes: **http://aplite:XX/**. The **XX** highlighted in the URL refers to the new Port number.

STEP 3

- Enter the default Admin Code 12345 and click on the **Logon** button. Access Portal LITE should start up, presenting you with the main Ribbon:



NOW Lets show you how easy it is to setup.

SETTINGS Menu



Tag Holders Reports Settings

Setup



Auto ID



Doors



Access Groups



Holidays



Reasons

Configuration



Date/time



Controller



Ethernet



UDP output



Security

System



Emergency Unlock



Lock Down



About

SETTINGS Menu (Configuration)



STEP 1 : Date/Time

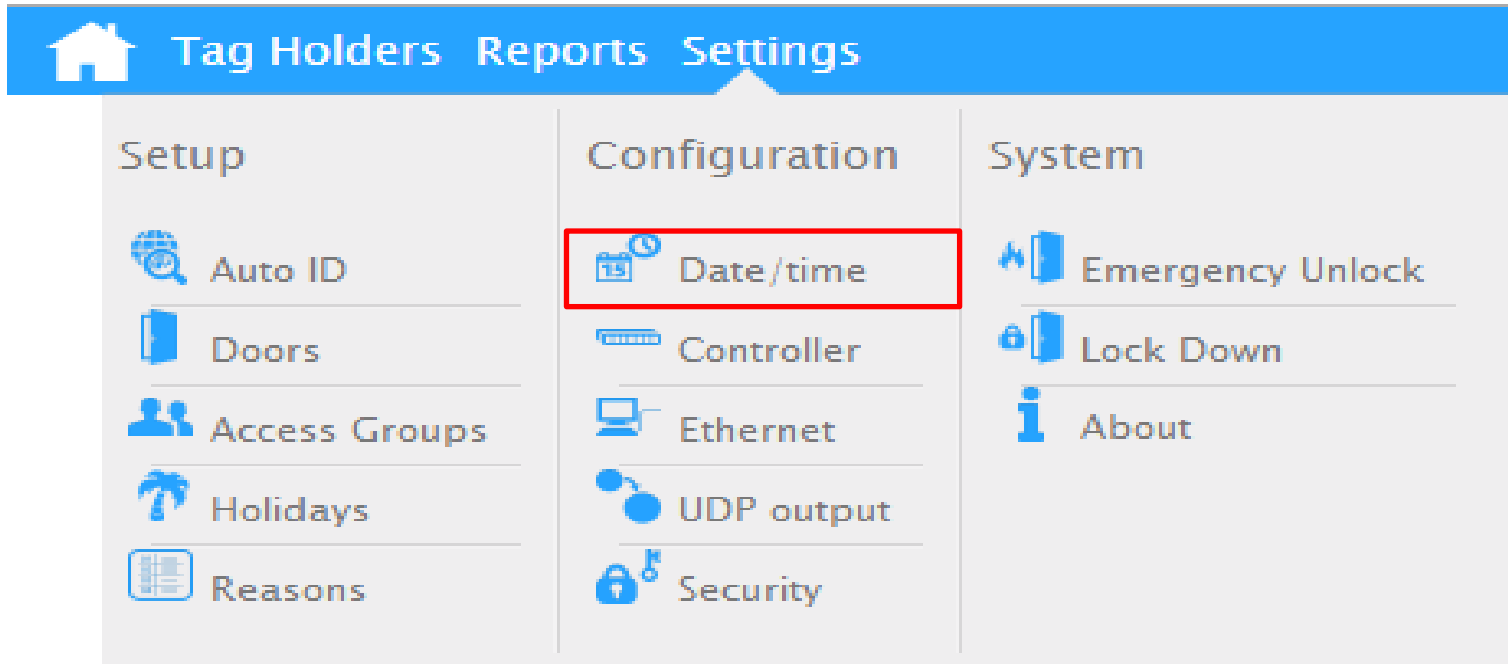

1. Synchronise the Cluster Controller Module's Date and Time to your PC 3

Optional:

1. Set the **Start** and **End Date**

2. Set the time that Daylight Savings takes effect using the **Switch Time** textbox.

4. Set the duration of the Daylight Savings time shift using the **Shift Duration** textbox.

STEP 2: Controller configuration

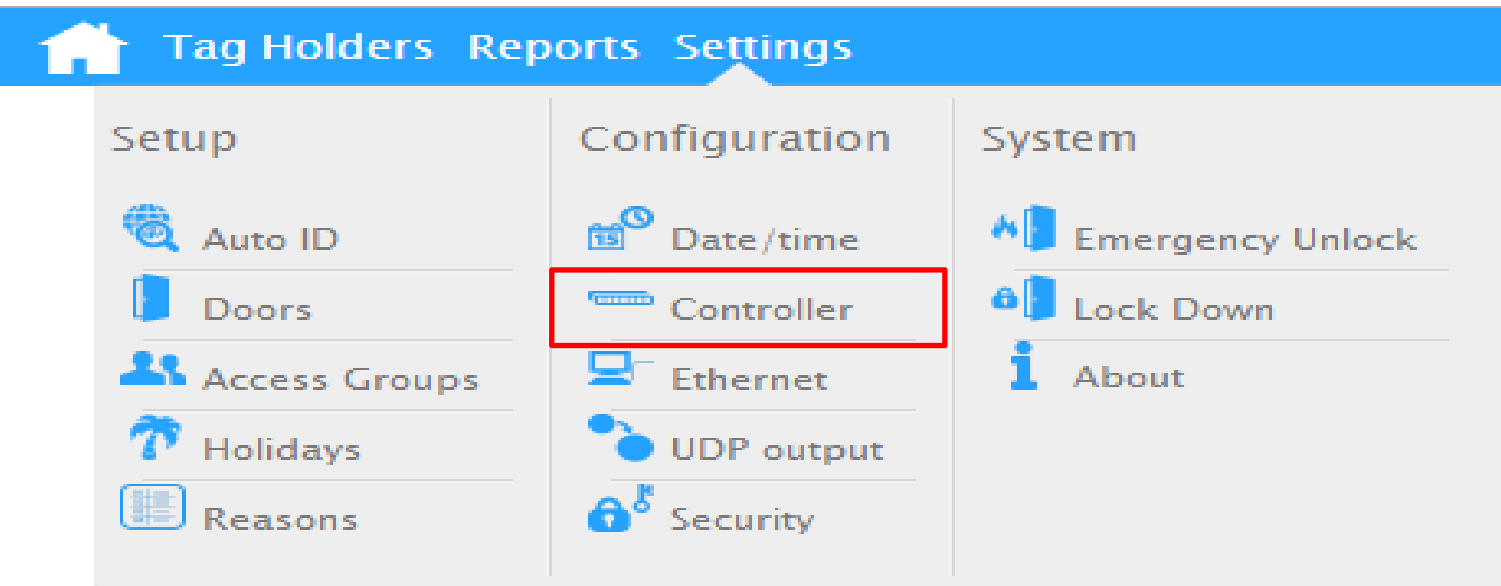

The screenshot shows the ACCESS portal navigation menu. The 'Settings' tab is selected. The menu is divided into three columns: Setup, Configuration, and System. The 'Controller' option in the Configuration column is highlighted with a red box.

- Home
- Tag Holders
- Reports
- Settings
 - Setup
 - Auto ID
 - Doors
 - Access Groups
 - Holidays
 - Reasons
 - Configuration
 - Date/time
 - Controller**
 - Ethernet
 - UDP output
 - Security
 - System
 - Emergency Unlock
 - Lock Down
 - About

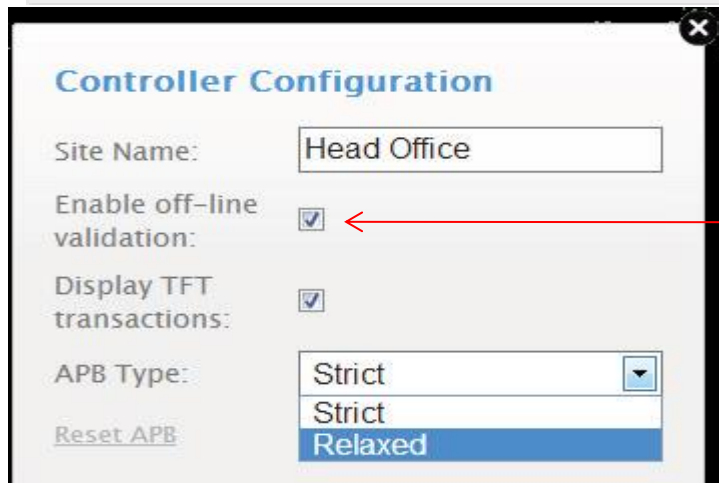

The screenshot shows the 'Controller Configuration' dialog box. The 'Enable off-line validation' checkbox is checked, and a red arrow points to it from the text box on the right. The 'APB Type' dropdown menu is open, showing 'Strict', 'Strict', and 'Relaxed' options.

Controller Configuration

Site Name:

Enable off-line validation:

Display TFT transactions:













APB Type:

[Reset APB](#)

The **Off-line Validation** checkbox is selected by default, allowing Terminals connected to the Controller to make certain access control decisions even when unable to communicate with the Controller. De-select the checkbox if necessary

STEP 3 : Ethernet

Home Tag Holders Reports Settings

Setup	Configuration	System
 Auto ID	 Date/time	 Emergency Unlock
 Doors	 Controller	 Lock Down
 Access Groups	 Ethernet	 About
 Holidays	 UDP output	
 Reasons	 Security	

Ethernet Config

Device Name:

Enable DHCP:

IP Address:

Subnet Mask:

Gateway:

DNS Server:

Controller Port:

Web Server Port:

This is the URL used to connect to the Web Interface.

The **Enable DHCP** checkbox is selected by default, de-select the checkbox to set a static IP Address for the Controller

Configure your CCM's network settings and make it static

Default Controller port : 10005 (leave as is)

This is where you will change the Web Server port. Default = 80

SETTINGS Menu (Setup)

STEP 4 : Auto ID

The Auto ID process will identify all the hardware and its fixed addresses

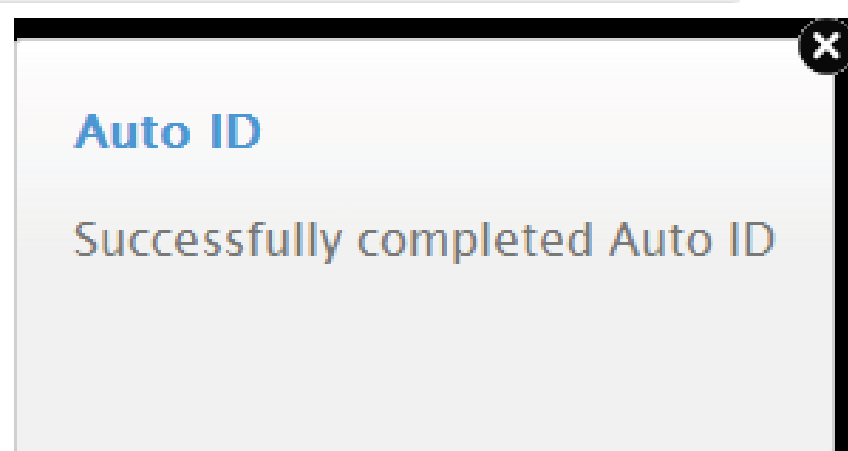
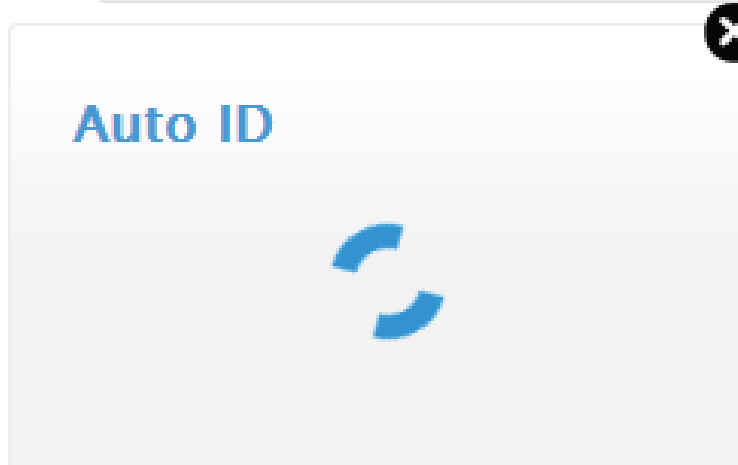
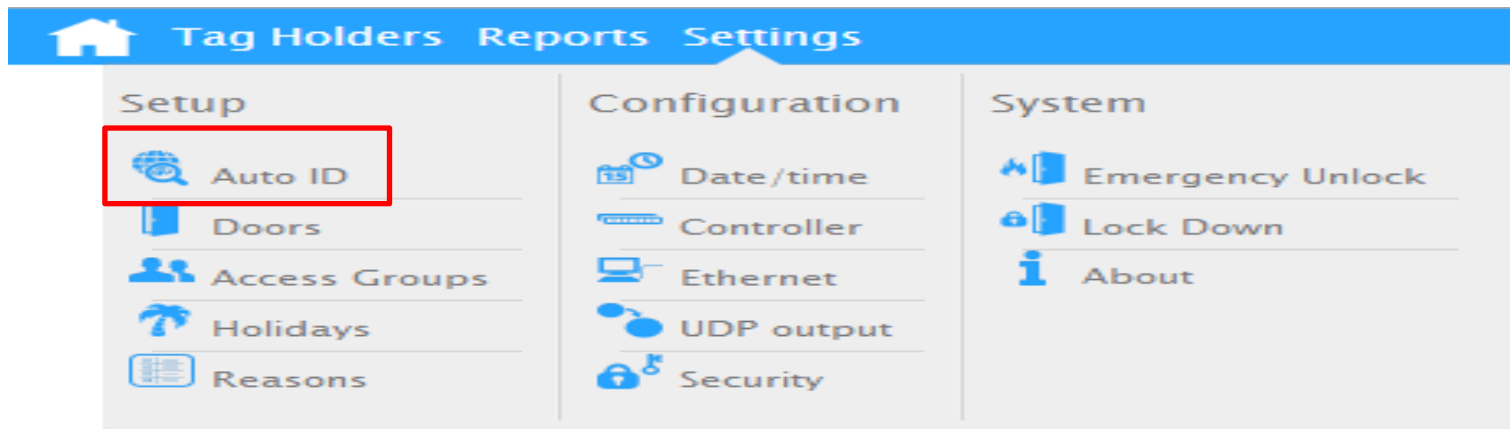

STEP 5 : Door Configuration



1. Configure your Door Template

Before adding any doors it is a good idea to first configure the **Door Template** settings. The Door Template settings become the default settings when you add a new door, so this can save you some time when adding a number of similar doors.

Door template

Anti-Pass back:

Entry reader

RTE mode:

DOS mode:

DOS usage:

Door open duration: (secs)

Strike duration: (x100ms)

Enable DOS line sensing:

Buzzer Volumes

Access allowed:

Access denied:

[next](#)

2. Add a new Door

The Access Portal LITE System supports:

- Maximum of **8** Doors
- **1** Anti-passback (APB) Zone.
- Each Door has a Door Mode Pattern, which is made up of a maximum of four time periods per any day.

Patterns may NOT overlap each other.

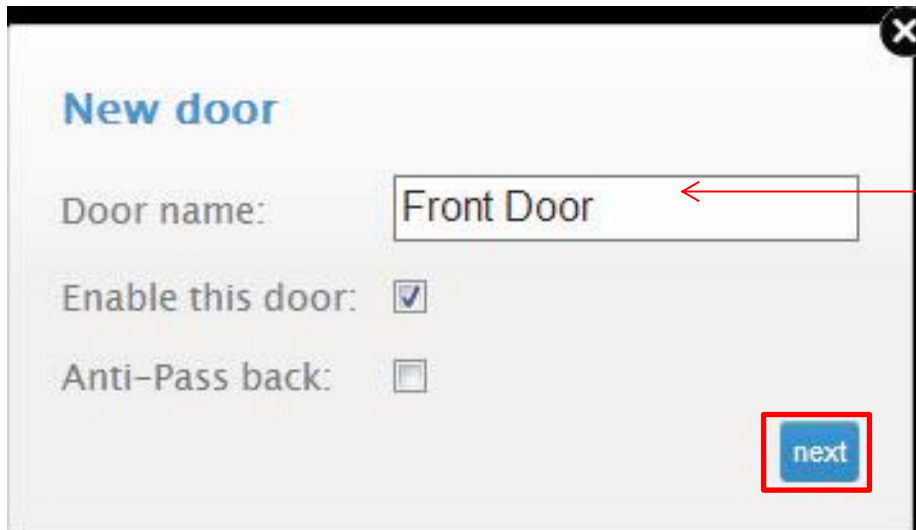

New door

Door name:

Enable this door:

Anti-Pass back:

Maximum **32** characters
in the **Door Name** textbox

3. Configure your Entry and Exit Readers

Select the **Entry Reader** using the drop-down list. Make your selection from the list of displayed list of Readers. This list will include ALL readers that were detected during Auto ID and **are not yet allocated to doors**.

Do likewise for the **Exit Reader** for this door, using the **Exit** drop-down list

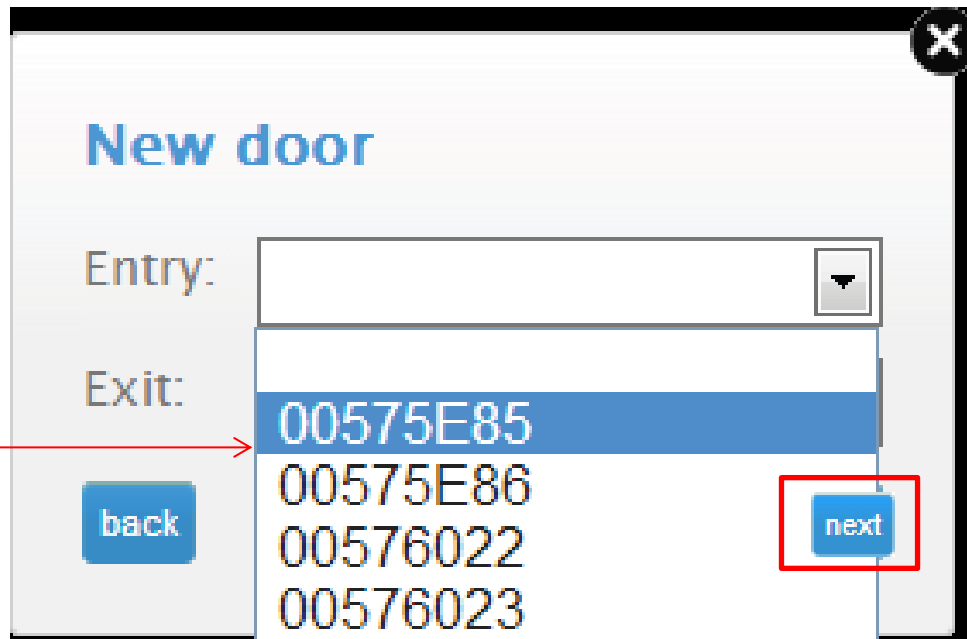

New door

Entry:

Exit:

- 00575E85
- 00575E86
- 00576022
- 00576023

back next

4. Configure Door Mode Patterns

New door

Default door mode: Tag Only

	MON	TUE	WED	THU	FRI	SAT	SUN	HOL
00:00								
01:00								
02:00								
03:00								
04:00								
05:00								
06:00	Remove							
07:00								
08:00								
09:00								
10:00								
11:00								
12:00								
13:00								
14:00								
15:00								
16:00								
17:00								
18:00								
19:00								
20:00								
21:00				Locked				
22:00								
23:00								

back Save

The default Door Mode is fixed on **Tag only**.

The following **rules** apply:

- There may only be **four** different areas per day. (in this image 3)
- Marked up areas cannot overlap.

Door Modes explained:

- **Locked**—the Door is locked and cannot be overridden with any Tag. In this Mode the Reader's LED **flashes Red**
- **Tag Only**—requires presentation of a Tag to open the Door. In this Mode the Reader's LED is **steady Red**
- **Tag + PIN-code**—requires presentation of a Tag followed by entry of a PIN-code to open the Door. PIN-codes range from **00000 to 65534**. After entering the PIN-code, complete the entry by pressing the **#** key). In this Mode the Reader's LED **blinks Red** then **Green**
- **Tag + Reason**—requires presentation of a Tag followed by entry of a Reason Code to open the Door. In this Mode, the Reader's Red LED follows a continuous cycle of brief **OFF blinks** (Long ON, Short off...)
- **Open on First Tag**—the Door is opened when the first valid Tag Holder presents their Tag and remains open. In this Mode the Reader's LED **flashes Green**
- **Unlock**—The door is unlocked. A Tag is not required to open the Door. In this Mode the Reader's LED is **steady Green**

SETTINGS Menu (Setup)

STEP 6: Access Groups



When the button is **GREEN** then it means the access group includes those days and doors

When the button is **PINK** it means those days and doors are excluded from the access group

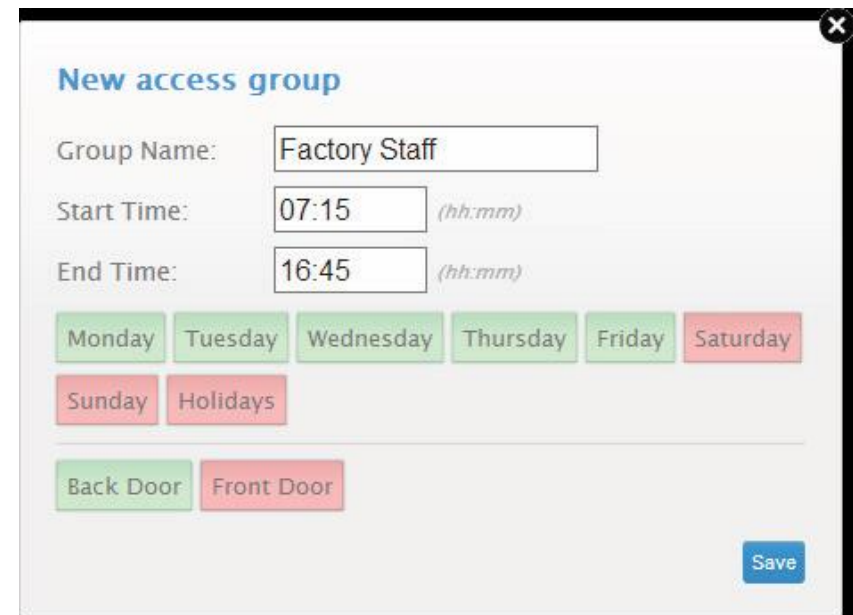

New access group

Group Name:

Start Time: (hh:mm)

End Time: (hh:mm)

Monday Tuesday Wednesday Thursday Friday Saturday

Sunday Holidays

Back Door Front Door

Save

STEP 7 :Holidays

(optional)



The Access Portal LITE System allows you to configure a **maximum of 18 Holidays**.

The screenshot shows the 'Settings' menu of the Access Portal LITE system. The menu is organized into three columns: Setup, Configuration, and System. The 'Holidays' option is highlighted with a red box.

Setup	Configuration	System
Auto ID	Date/time	Emergency Unlock
Doors	Controller	Lock Down
Access Groups	Ethernet	About
Holidays	UDP output	
Reasons	Security	







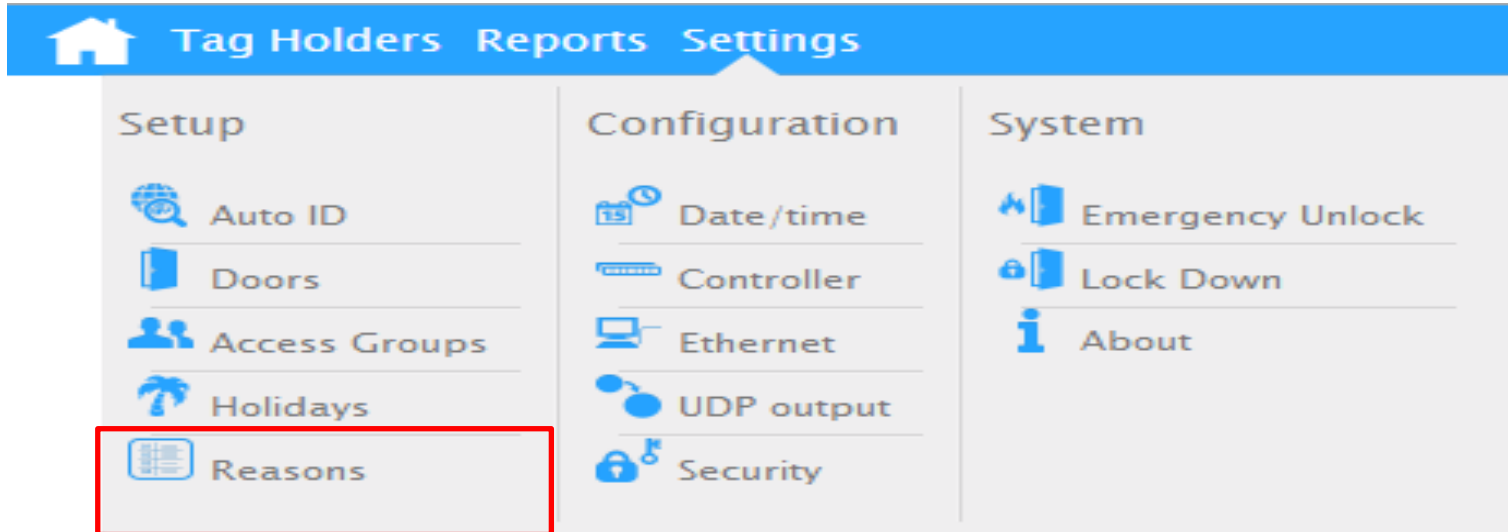





STEP 8: Reasons

(optional)

The Access Portal LITE System allows for storage of **up to 10 Reason Codes**. You may assign any number between **1** and **99** as a Reason Code.



The screenshot shows the 'Settings' menu in the Access Portal. The menu is divided into three columns: 'Setup', 'Configuration', and 'System'. The 'Reasons' option in the 'Setup' column is highlighted with a red box.

Setup	Configuration	System
 Auto ID	 Date/time	 Emergency Unlock
 Doors	 Controller	 Lock Down
 Access Groups	 Ethernet	 About
 Holidays	 UDP output	
 Reasons	 Security	



The screenshot shows the 'Settings' menu with the 'Reasons' option selected. The 'Welcome' message is visible in the top right corner.

Tag Holders Reports Settings *Welcome*



The screenshot shows the 'Reasons' management interface. It features a 'Reasons' icon, the text 'Reasons', and an 'add' button with a plus sign.

 **Reasons** 

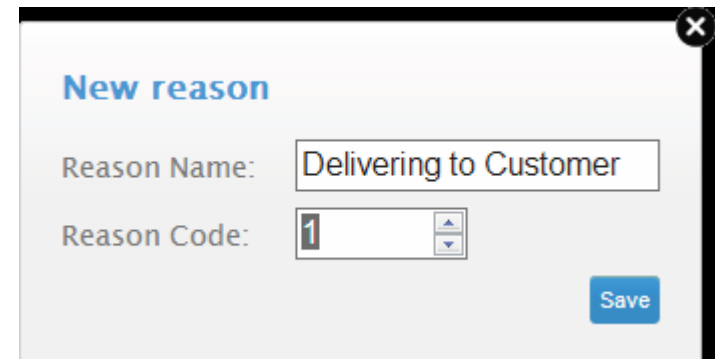

The screenshot shows the 'New reason' form. It includes a 'Reason Name' field with the value 'Delivering to Customer' and a 'Reason Code' field with the value '1'. A 'Save' button is located at the bottom right.

New reason

Reason Name:

Reason Code:

TAG HOLDERS Menu



Tag Holders Reports Settings



Tag Holders

 add



Tag Holder Template



Add a Batch of Tag Holders

Up to 1000 Tag Holders
3 Tags per Tag Holder

STEP 9 : ADD a new tag holder

X

New tag holder

First name:

Last name:

Access level: 

Pin-code:

Custom field:

Tag Code: 

Save

ACCESS LEVELS
Visitor—restricted access, valid for day of issue only.

Normal—employee Tagholder, access restricted by Door Mode.



Administrator—overrides Anti-passback (APB) rules

 Tag Holders 

 Tag Holder Template

 Add a Batch of Tag Holders





Tom Jones

Normal   





Note – The colour of the tag icons indicates the status of the tags stored under these icons:

After saving the first **Tag Holder**, you will see that Tag Holder displayed on the **Tag Holders** screen

-  A GREY tag means there is no tag information stored
-  A BLACK tag will become active in the FUTURE
-  A GREEN tag is ACTIVE
-  A RED tag is SUSPENDED (manually disabled)
-  A PINK tag has EXPIRED

Tom Jones Normal

Tag Code: 

Access group: 

Start date: 

End date: 

Suspend tag 

Click on the Tag Icon whose data you wish to edit



STEP 1

To capture the Tag Code by scanning the Tag, click on the  icon

STEP 2

Choose the desired Entry or Exit Reader from the list that appears

STEP 3

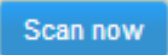
While the Tag is presented to the Reader, click on the  button to scan the Tag. The scan is completed within 1.5 seconds, and displayed in the Tag Code entry box

STEP 4

Complete the Start and End Date requirements using the  buttons

STEP 5













If necessary, select the **Suspend Tag** checkbox, which will render this tag unusable

STEP 6

Click the  button

ADDITIONAL Configuration

 Tag Holders Reports Settings

Setup	Configuration	System
 Auto ID	 Date/time	 Emergency Unlock
 Doors	 Controller	 Lock Down
 Access Groups	 Ethernet	 About
 Holidays	 UDP output	
 Reasons	 Security	

UDP Output

The UDP Output feature sends events generated in the Access Portal LITE System to a third-party application.

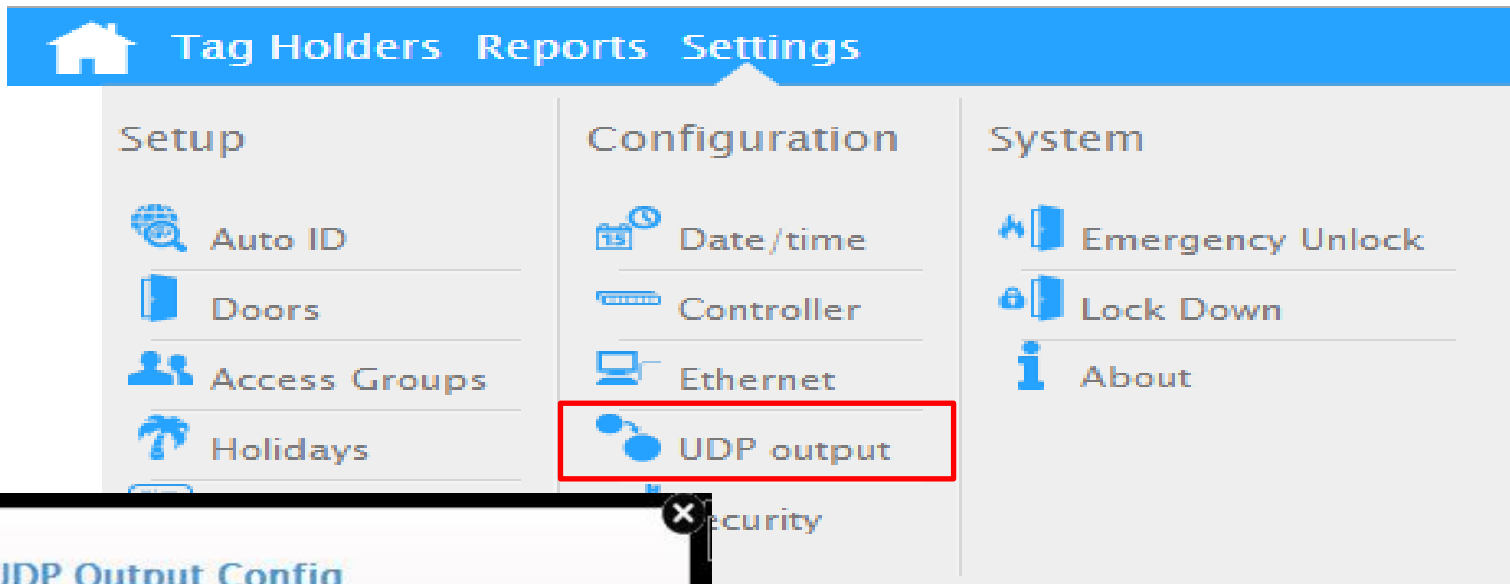

UDP Output Config

Enable UDP Output:

Receiving IP Address:

Receiving Port:

Keep-Alive Time:













Save

Complete the **Receiving IP Address** textbox

The default Receiving Port Number is **10010**. Only change this Port Number if it clashes with other devices or services on your network.

Security

 Tag Holders Reports Settings

Setup	Configuration	System
 Auto ID	 Date/time	 Emergency Unlock
 Doors	 Controller	 Lock Down
 Access Groups	 Ethernet	 About
 Holidays	 UDP output	
 Reasons	 Security	

You can change the administrator password which is **12345** by default

SYSTEM

Emergency Unlock & Lock Down



Home Tag Holders Reports Settings

Setup	Configuration	System
Auto ID	Date/time	Emergency Unlock
Doors	Controller	Lock Down
Access Groups	Ethernet	About
Holidays	UDP output	
Reasons	Security	

Emergency Unlock



Note – In case of an emergency evacuation, or similar event, this will UNLOCK every door that is controlled by the system



Tag Holders Reports Settings

EMERGENCY OPEN – All doors are unlocked



[Revert to normal state](#)

ALL Doors will unlock - and will remain unlocked until you click on  [Revert to normal State](#) - at which point normal operation will immediately return

Lock Down



Note – This locks all doors on the system, no tags or codes will be able to open any door



Tag Holders Reports Settings

LOCKDOWN – All doors are locked















[Revert to normal state](#)

ALL Doors will lock - and will remain locked until you click on  [Revert to normal State](#) - at which point normal operation will immediately return

About

 Tag Holders Reports Settings

Setup	Configuration	System
 Auto ID	 Date/time	 Emergency Unlock
 Doors	 Controller	 Lock Down
 Access Groups	 Ethernet	 About
 Holidays	 UDP output	
 Reasons	 Security	

About

Impro Technologies (Pty) Ltd

Copyright © 2000 - 2013

Firmware Version: 4.27

Website Version: pre-release

REPORTS Menu

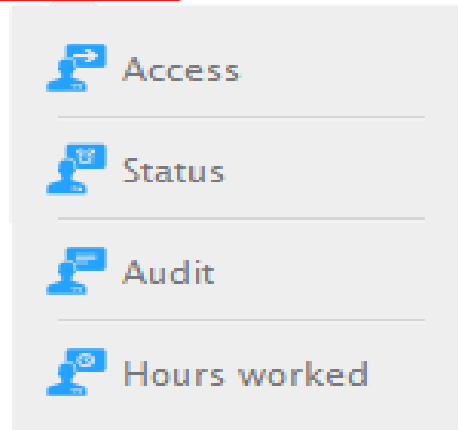

Report categories



- **Access** — *this Report provides access data for the selected Tagholder over a specified date range.*
- **Status** — *this Report displays all the status transactions from Controllers and Terminals on a selected date.*
- **Audit** — *this Report provides a list of Tags added, edited or deleted over a specified date range.*
- **Hours Worked** — *this Report calculates hours worked from the IN and OUT Transactions of the Anti-passback (APB) Zone.*



Set the Report's **Start** and **End Date** using the  buttons

From: 16-09-2013 

To: 26-09-2013 

Run report

Download

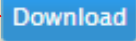

Status Report

Click the  button to save the report as a CSV file. This can be opened and edited in a spreadsheet application, such as Microsoft's Excel

DATE	TIME	NAME	LOCATION	EVENT	TAGCODE	DESCRIPTION
2013-09-19	09:32:24		Controller	Tables Initialised		
2013-09-19	09:32:24		Controller	Unit Power up		
2013-09-19	09:32:42		Front (Entry)	Unit Power up		
2013-09-19	09:32:44		Front (Exit)	Unit Power up		
2013-09-19	09:32:46		Back (Entry)	Unit Power up		
2013-09-19	09:32:48		Back (Exit)	Unit Power up		
2013-09-25	16:47:33		Controller	Lockdown Mode On		
2013-09-25	16:47:46		Controller	Emergency Mode Off		

Firmware Upgrade Utility

- Used to Upgrade unit **Firmware**
- Used to **Backup** and **Restore** your unit.

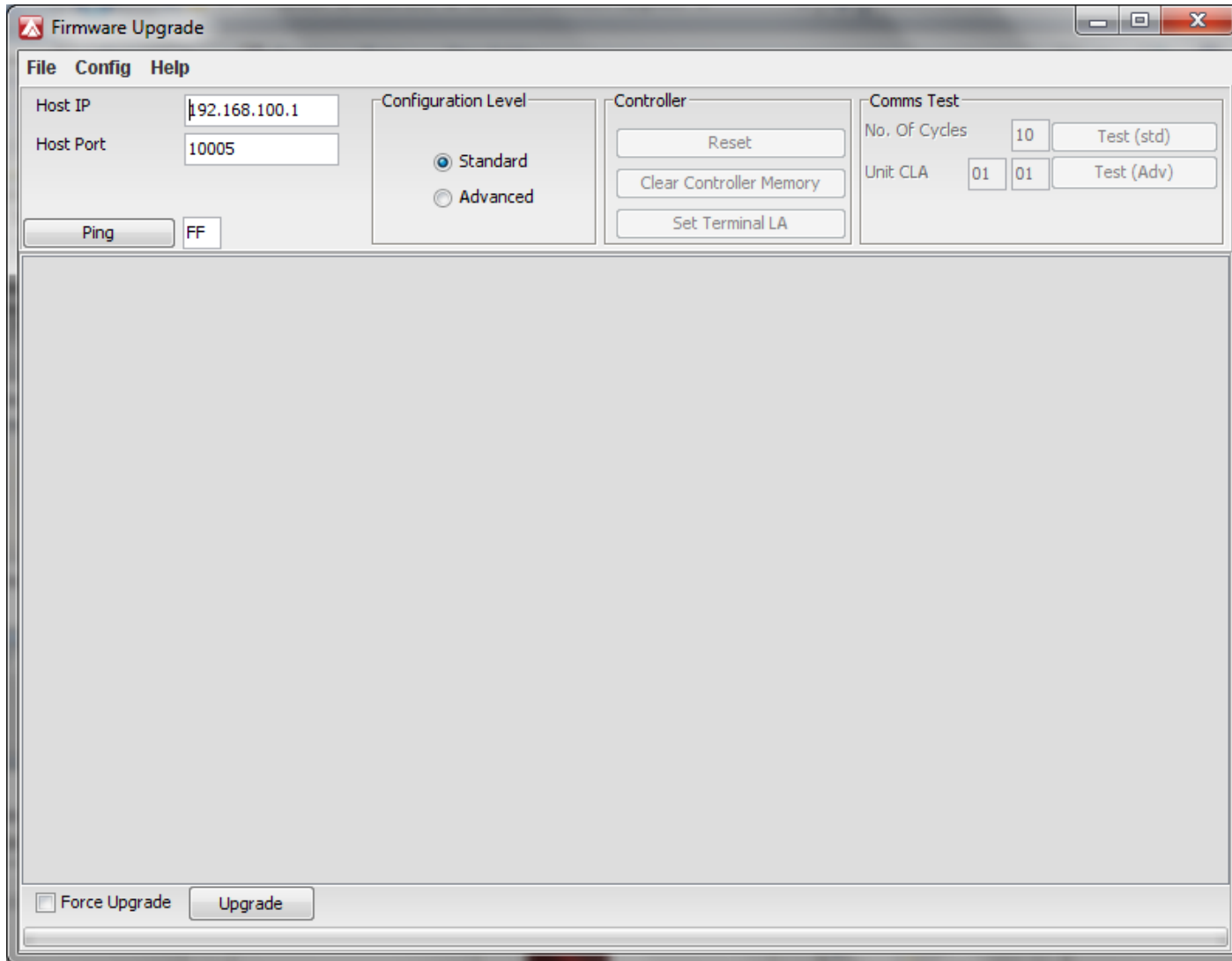

Install the upgrade tool to C:\ by double clicking **APLiteFU.msi** and follow prompts

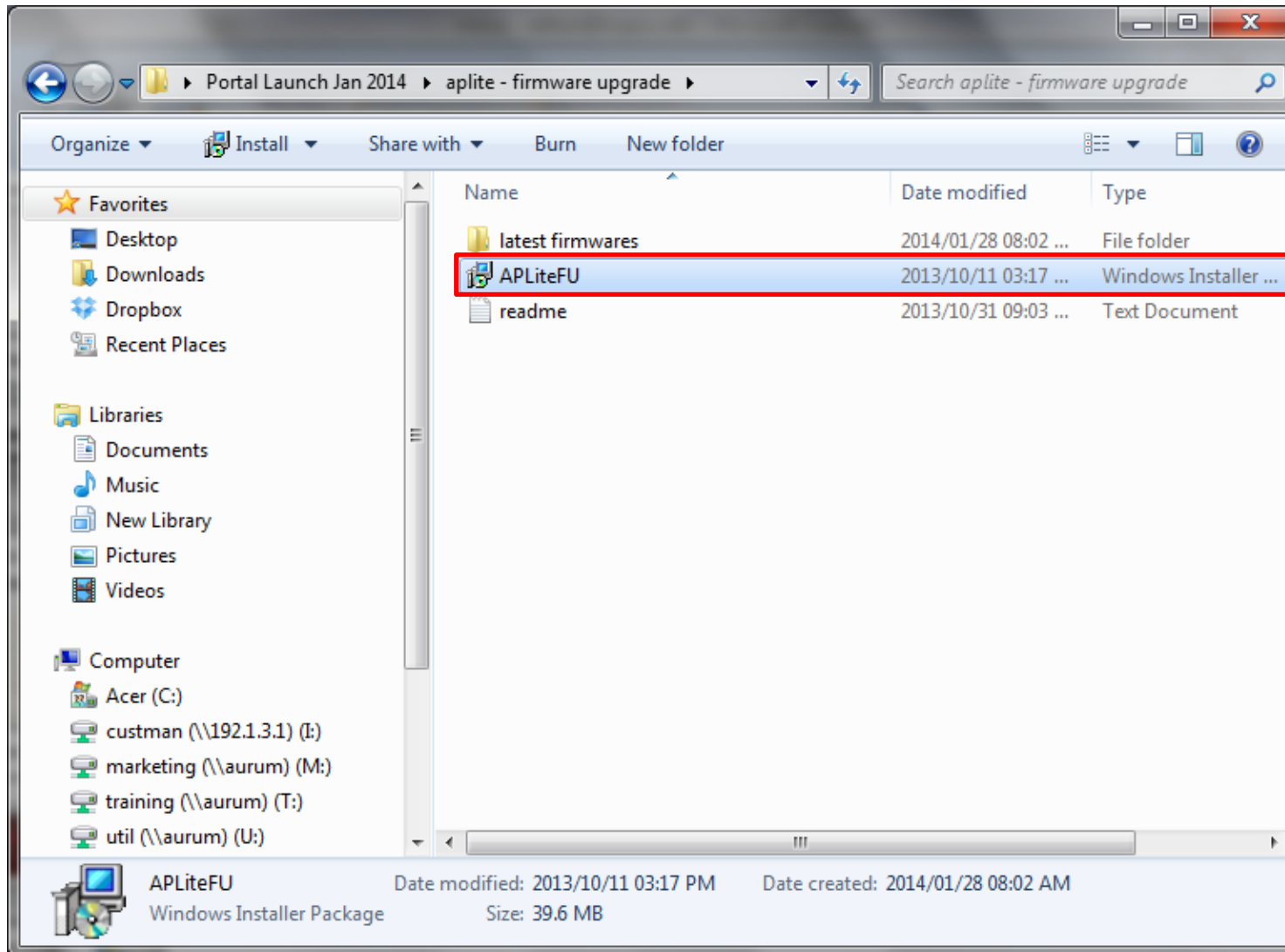

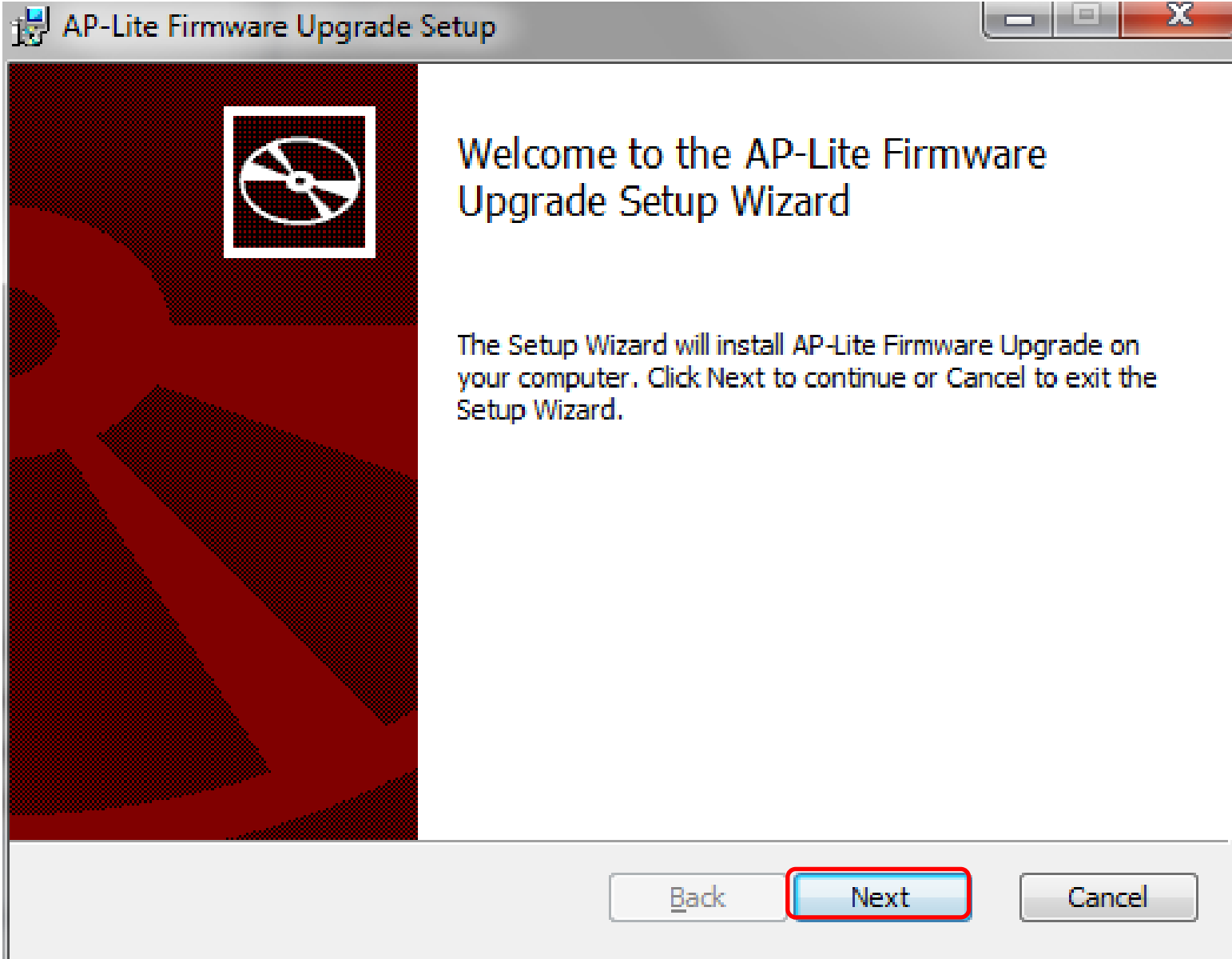

AP-Lite Firmware Upgrade Setup

End-User License Agreement

Please read the following license agreement carefully

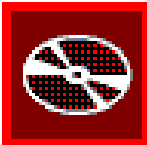

Impro Technologies (Pty) Ltd - SOFTWARE
LICENCE AGREEMENT

READ AND ACCEPT THE TERMS AND CONDITIONS OF
THIS LICENCE AGREEMENT BEFORE PROCEEDING WITH
THE INSTALLATION OF THIS COMPUTER SOFTWARE AND
THE ACCOMPANYING USER DOCUMENTATION (THE
"PROGRAM"). SHOULD YOU DECIDE TO PROCEED WITH
THE INSTALLATION, THEN YOU SHALL BE DEEMED TO
HAVE ACCEPTED THESE TERMS AND CONDITIONS, AND
YOU WILL BECOME A LICENSEE THIS LICENCE

I accept the terms in the License Agreement:

Print Back **Next** Cancel

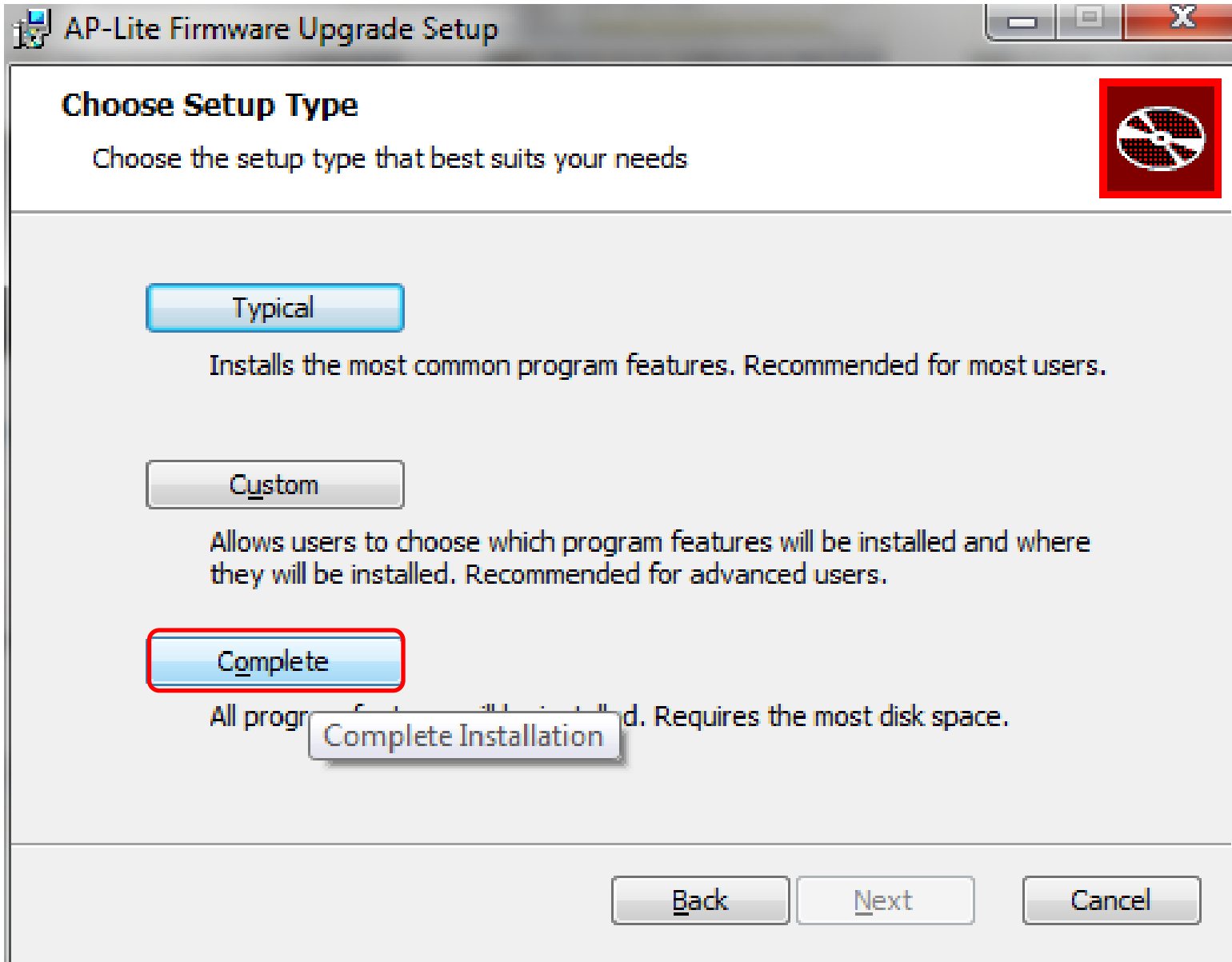

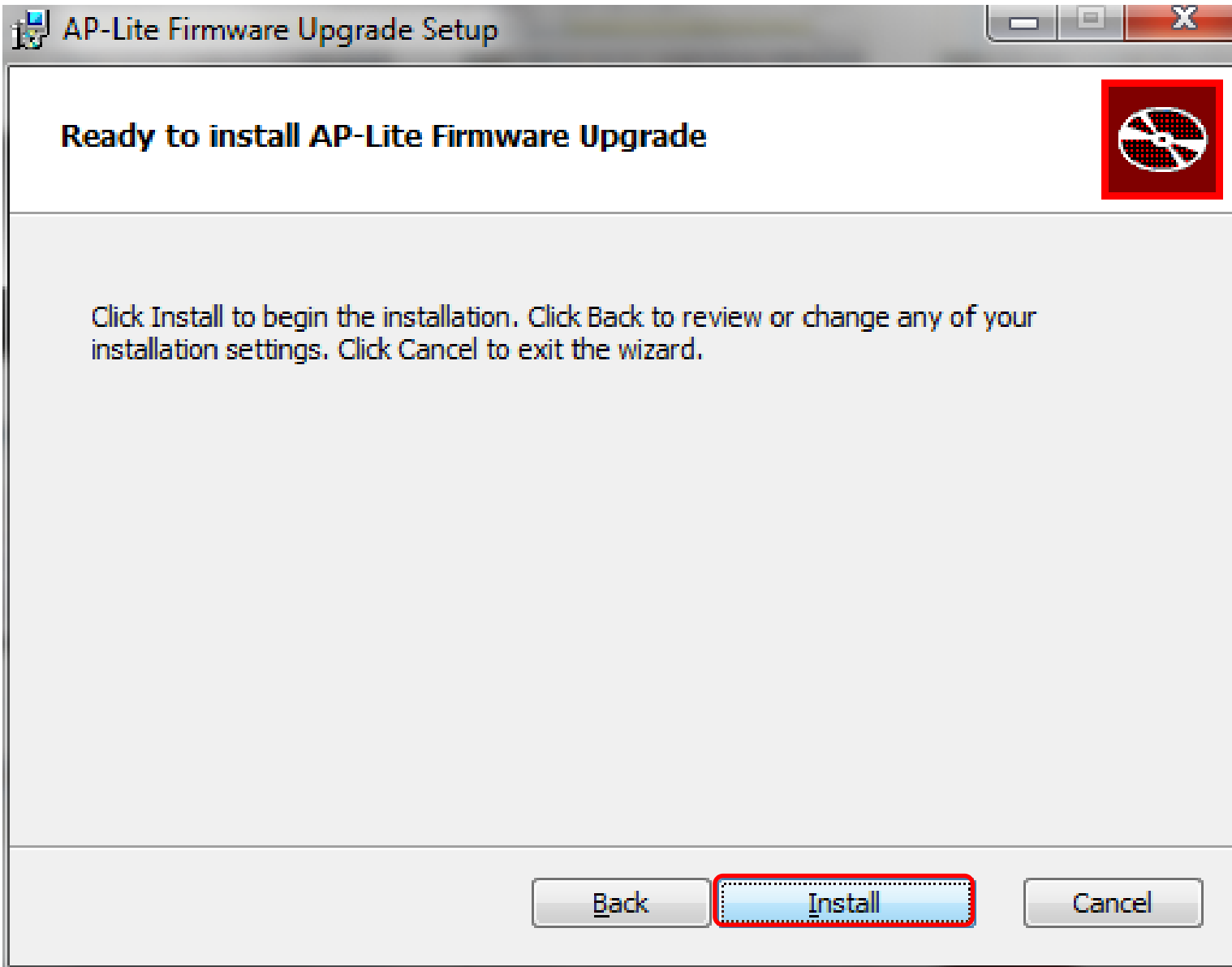

AP-Lite Firmware Upgrade Setup

Installing AP-Lite Firmware Upgrade

Please wait while the Setup Wizard installs AP-Lite Firmware Upgrade.

Status:

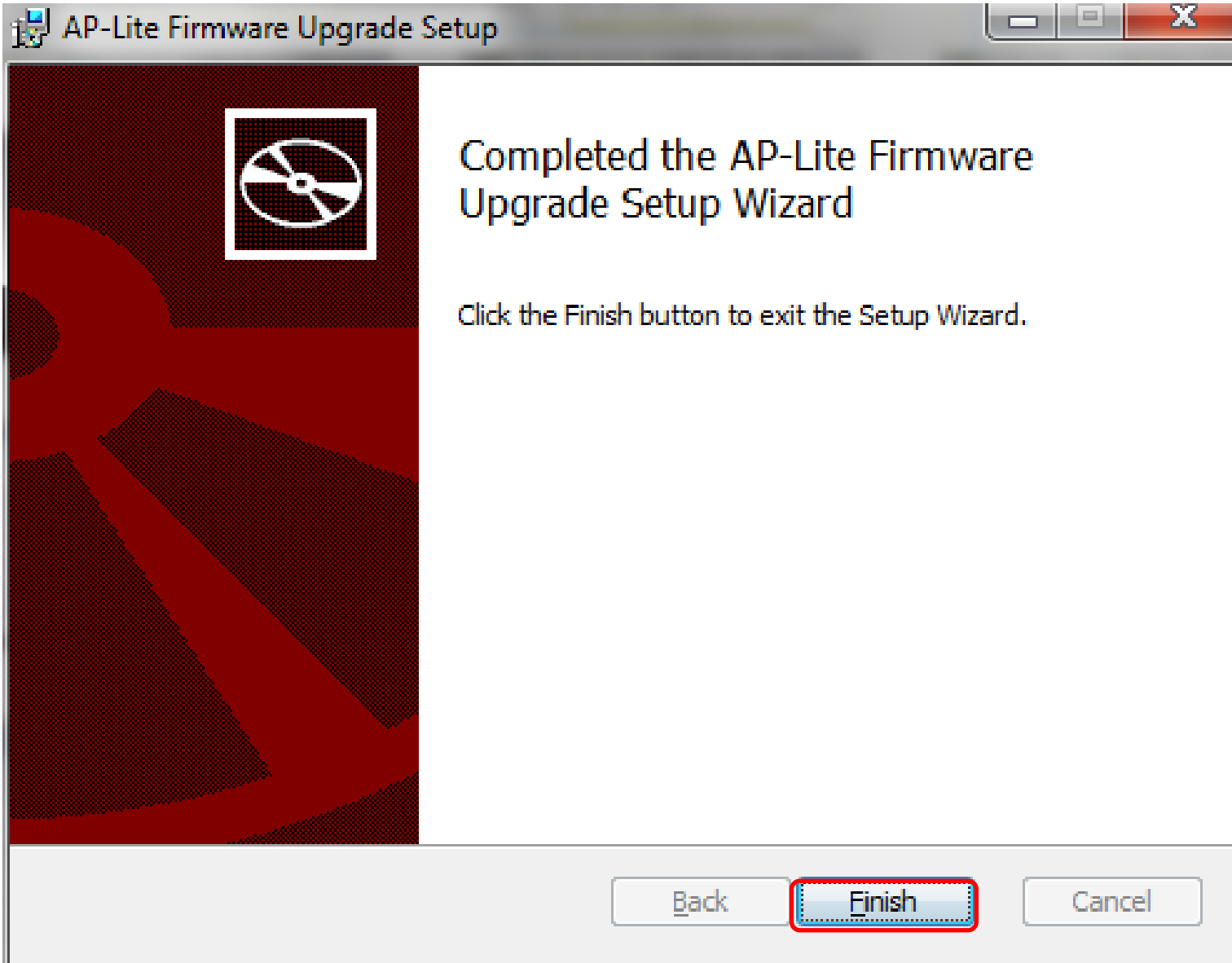

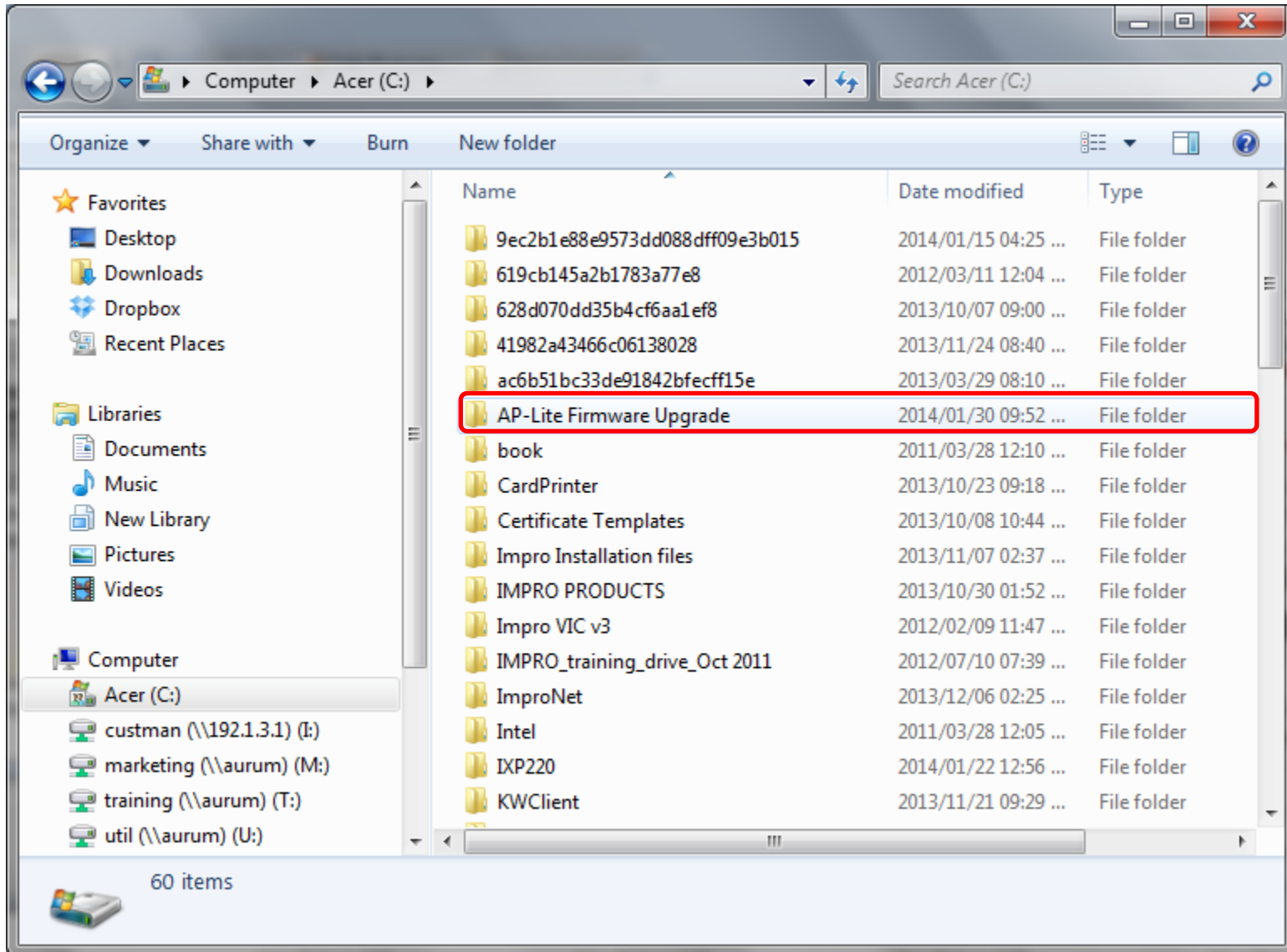

Firmware Upgrade

File **Config** **Help**

Backup databases 168.100.1
Restore databases

Choose Locale
Translate
Exit

Configuration Level
 Standard
 Advanced

Controller
Reset
Clear Controller Memory
Set Terminal LA

Comms Test
No. Of Cycles: 10 Test (std)
Unit CLA: 01 01 Test (Adv)

Force Upgrade **Upgrade**

Replacing a faulty Cluster Controller



In the event that the Cluster Controller Module is replaced with a new unit **all settings are lost**

All Tag Holder data, etc, will have to be re-entered/enrolled again.

In the event that the replacement Cluster Controller Module is not new, it is important to reset it to

factory default

condition before setting it up, this will ensure that the settings are correct for your installation.

Troubleshooting

If the unit was previously connected to the LAN and had a DHCP/ user assigned address, this is saved in memory.

Even if the DHCP server is off, the last known IP address is always used by the unit. The only way to clear this is via a **Factory default** to revert it back to 192.168.100.1.

THANK YOU